

## **HOSTAFORM® POM**

POLYOXYMETHYLENE  
COPOLYMER







**HOSTAFORM® POM**  
POLYOXYMETHYLENE COPOLYMER

# Table of Content

<b>1</b>	<b>Introduction</b>	<b>6</b>
<b>2</b>	<b>Grades, supply form, color range, quality assurance</b>	<b>8</b>
<b>3</b>	<b>Physical properties</b>	<b>34</b>
3.1	Mechanical properties	34
3.1.1	Properties under short-term stress	35
3.1.2	Properties under long-term stress	36
3.1.3	Properties under impact stress	40
3.1.4	Properties under cyclic stress	43
3.1.5	Surface properties	44
3.1.6	Tribology/Slip and wear properties	46
3.2	Thermal properties	56
3.3	Electrical properties	58
3.4	Optical properties	60
<b>4</b>	<b>Effect of the service environment on the properties of Hostaform® POM</b>	<b>61</b>
4.1	Properties in air at elevated temperatures	61
4.2	Properties in water	63
4.2.1	Water absorption	63
4.2.2	Service temperature in hot water	63
4.2.3	Resistance to chlorinated drinking water	65
4.3	Fuel resistance	66
4.3.1	Diesel Exhaust Fluid	69
4.4	Chemical properties	70
4.4.1	Chemical resistance	70
4.4.2	Gas and vapor permeability	73
4.5	Resistance to light and weathering	74
4.5.1	General	74
4.5.2	UV test methods	74
4.5.3	UV Stabilized Grades	75
4.6	Resistance to high-energy radiation	78
4.7	Flammability	78
4.8	Regulatory Status	79
4.8.1	Food/drinking water contact	79

4.8.2	Pharmaceutical/Medical applications	79
<b>5</b>	<b>Processing</b>	<b>81</b>
5.1	Safety recommendations	81
5.2	Injection molding	83
5.2.1	Machine requirements	83
5.2.2	Processing conditions	83
5.2.3	Flow properties and flow path length	85
5.2.4	Shrinkage	86
5.2.5	Gate and mold design	88
5.2.6	Precision injection molding	88
5.3	Extrusion	94
5.3.1	Extruder and screw	94
5.3.2	Material grades	94
5.3.3	Extrusion of round bars	94
5.3.4	Extrusion of sheets and flat bars	95
5.3.5	Extrusion of pipes and hollow profiles	95
5.3.6	Annealing	95
5.4	Extrusion blow molding	96
5.5	Injection blow molding	97
5.6	Assembly of moldings and semifinished products	98
5.7	Surface decoration	99
5.7.1	General surface requirements	99
5.7.2	Painting	100
5.7.3	Vacuum metallizing	100
5.7.4	Electroplating	100
5.7.5	Hot stamping	101
5.7.6	Laser marking	101
5.8	CAMPUS plastics database	103
5.9	Shelf-life of Hostaform® POM	103
<b>6</b>	<b>Recycling Hostaform® POM</b>	<b>104</b>
<b>7</b>	<b>Literature</b>	<b>105</b>

# 1

## Introduction

Polyoxymethylene (POM) homopolymer chemical formula  $(-O-CH_2-)_n$  was first introduced to the market by DuPont in the early 1960s as an engineering thermoplastic that could substitute for metal.

The successes of POM in metal replacement applications led to the introduction of Celcon® POM (1962) and Hostaform® POM (1963), both acetal copolymers (POM-C).

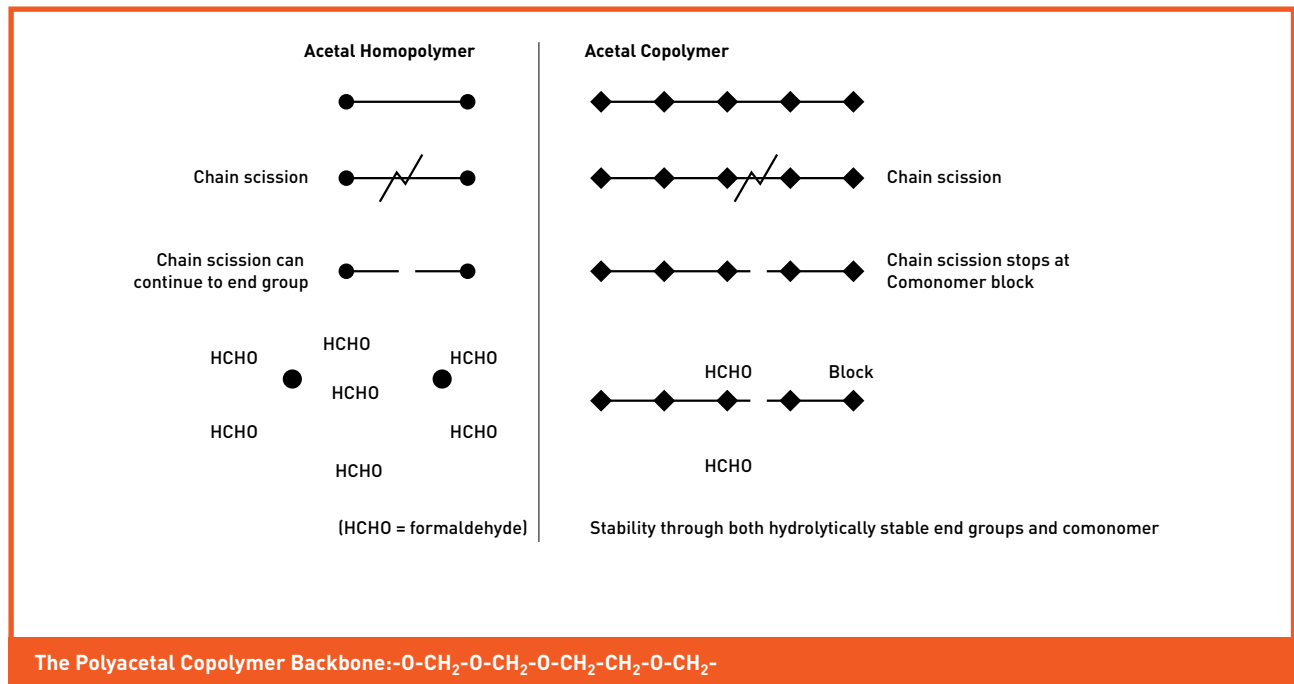
The copolymer was a step change in improvement to chemical/fuel and UV resistance, and long-term thermal stability versus the homopolymer. This advantage enabled Celanese, aided by our strong technical expertise, to develop the broadest portfolios to date in the industry.

Today's latest advancements not only support the ever-changing landscape, but also challenge the mindset of engineers globally.

Celanese isn't just a high-quality raw material supplier of engineering polymers. Our customers utilize our ability to provide them with in-depth technical information required to optimize component design and process conditions. These factors have enabled us to become the leading supplier of POM globally.

### Typical attributes of Hostaform POM®/Celcon POM®

- ▶ Good mechanics – high stiffness-to-strength ratio
- ▶ Good dimensional stability over a broad temperature range: -40 to 100 °C
- ▶ Excellent electrical and dielectric properties > 550 V
- ▶ Inherent sliding properties
- ▶ Broad chemical resistance to solvents, cleaners, fuels, oils, and strong alkalis, pH 4 to pH 14
- ▶ Sustained toughness (below -40 °C)
- ▶ No environmental stress cracking
- ▶ Excellent resilience – ability to recover original shape after stress has been removed
- ▶ Excellent process robustness – good thermal stability



Celanese is truly innovative and continuously extends the Hostaform®/Celcon® (POM) product line to complement its broad portfolio to fulfill application needs in ever-diversifying markets.

Celanese also addresses new initiatives/directives in ever-changing industries, where we have a broad portfolio of the following:

- ▶ Grades with improved heat distortion temperature and stiffness

---

- ▶ Reinforced grades for improved heat distortion, temperature and stiffness

---

- ▶ High-impact grades with step-change improvement in energy absorption

---

- ▶ Grades with improved media resistance

---

- ▶ Conductive grades to dissipate or conduct electrical charges

---

- ▶ Medical- and pharmaceutical-compliant grades where stringent requirements are enforced

---

- ▶ Low-emission grades for automotive interior applications

---

- ▶ Appearance effects, laser marking, low gloss and metallic-effect product

---

- ▶ Improved friction and wear grades

---

- ▶ Highest performance grades for tribological applications

#### **Grades, supply form, color range, quality assurance**

The basic grades are designated by a letter (C or M) followed by two to five digits, of which the first two or three represent the melt flow rate. For example, Hostaform® POM C 9021 is a basic grade with a melt flow of approximately 9.0. More detailed information can be found at [www.celanese.com](http://www.celanese.com).

Hostaform® POM S is the designation for elastomer-modified, impact-resistant grades based on Hostaform® POM C 9021 or C 27021. The last digit indicates the level of increased toughness in each case. For example, Hostaform® POM S 9364 is tougher than Hostaform® POM S 9363.

Depending on the type and content of additive used, the modified grades differ from the Hostaform® POM basic grades not only in terms of the physical properties but also in their resistance to environmental effects. This applies particularly to the Hostaform® POM S grades because of their chemical structure (blends with elastomer components).

Hostaform® POM is supplied as opaque-white, natural or colored granules or pellets with a particle size of approximately 3 mm. It is normally packed in 25 kg to 1000 kg containers. Some grades are also available in bulk amounts. For more information, contact your account manager.

## 2

## Grades, Supply Form, Color Range, Quality Assurance

### The letter suffixes have the following meanings:

AE	Advanced extrusion
AM	Antimicrobial
AS	Antistatic finish
AW or SW	Special tribological/wear additives
Black 10/1570	Special formulation UV-stabilized and carbon black, properties slightly lower than for standard grades. Not available for all grades.
C, M	Standard grades, letter precedes grade number
EC	Electro conductive/electrostatic dissipative
FK, M90-07	Color concentrate/masterbatch
G	GUR® UHMW-PE
GV1, GC	Glass couple/glass-fiber grade
GV3, GB	Glass bead
HP	High performance
K	With special chalk
LG	Low gloss
LM	Laser markable
LS, UV...Z, xxUV	UV/Light stabilized
LT	Laser Transparent
LW	Low wear – tribological grade
LX	MetalX™ – specialty appearance grade
M	Molybdenum disulphide, letter follows grade number
MC	Mineral coupled
MR	Media resistant
MT	Medical technology
SLIDEX	Lowest wear, friction and noise
S OEK	Masterbatch based on Hostaform C 9021 with silicone oil
RM	Friction reducing
S	Impact modified
TF	PTFE
WR, WS	Weather resistant – black only
XT	Extreme toughness
XAP®, XAP <sup>2</sup> ™	Low emission grades, available as natural or colored pellets in different melt flow rates
XAP <sup>2</sup> LS	Low emission grade with a light-stabilized formulation

Note: Common abbreviations can come before or after grade number

## Comparison of Hostaform® POM and Celcon® POM Acetal Grades

Description	Hostaform® POM	Celcon® POM	Description	Hostaform® POM	Celcon® POM
▶ General Purpose Unfilled	C 2521, C 9021 C 13021, C 27021 C 52021	M25, M90™ M140, M270™	▶ Low Wear	C9021 K	LW90
▶ High Modulus Unfilled	M15HP, C 13031	M15HP	Low PTFE		LW90-F2
▶ Impact Modified			Medium PTFE	C 9021 TF5	
Best balance of weld line, stiffness, strength and impact			High PTFE	C 9021 TF	LW90-FS
Moderate	S 9362		Silicone Containing		LW90-S2
Medium	S 9363		Silicone Concentrate	C 9021 S OEK	LW90-SC
High	S 9364		▶ Low Wear/Low Noise	C9021 AW C 9021 SW	M140-L1 M90AW M90SW
Super Tough	XT20, XT90		▶ Antistatic	27021 AS	
Ultimate weld line performance and low temperature impact			▶ ESD Grades		
Medium	S 9243 XAP <sup>2™</sup>		Carbon Powder	EC140XF, EC270TX	
High	S 9244 XAP <sup>2</sup>		Stainless Fiber		CF802
▶ Extrusion Grades	M25AE		Carbon Fiber Reinforced	EC140CF10	
▶ Low Emission Grades			▶ UV Resistant**	CXX LS*	UVXX*Z, Mxx-45Ht
Standard	M25XAP®, C 2521 XAP <sup>2</sup> , M90XAP®, C 9021 XAP <sup>2</sup>		Low Gloss UV	UV130LGX	UV140LG
UV	M90-45XAP, C9021 LS XAP <sup>2</sup>		Reduced Gloss UV		LU-02
Impact Modified	TF-10XAP®, S 9362 XAP <sup>2</sup> , S 9363 XAP <sup>2</sup> , S 9364 XAP <sup>2</sup>		▶ Appearance		
Reduced Gloss	UV140LG XAP®		Metal Effects	LX90 (non-UV-Stable) LX90Z (UV-Stable) LX90GC15	
▶ Media Resistant Grades			Color Concentrates	FK	M90-07
Intermittent Bleach	MR130HPB	MR25B MR90B MR270B	Laser Markable	LM90, LM25	
Household Cleaners	MR130ACS		Laser Markable Low Gloss	LM140LG	
Diesel Fuel	C 13031 XF		UV Laser Markable		LM90Z
▶ Glass Reinforced Grades			UV Laser Markable Low Gloss	LM140LGZ	
10%	C 9021 GV1/10	GC10	▶ Medical Technology		
20%	C 9021 GV1/20		Unfilled Grades	MT8U01, MT2U01 MT12U01, MT24U01	
25-26%	C9021 GV1/30	GC25A	High Modulus	MT12U03	
▶ Glass Bead Grades			UV Detectable	MT8U05	
10%	C 9021 GV3/10		Low Wear Grades		
20%	C 9021 GV3/20		Low PTFE	MT8F01, MT24F01	
25%		GB25	High PTFE	MT8F02	
30%	C 9021 GV3/30		XX* melt flow rate code, i.e., C9021 LS, M90-25, UV90Z		
▶ Mineral Filled					
Low		MC90, MC270			
High		MC90-HM, MC270-HM			

### Color – Looks That Thrill™

Celanese offers a broad range of colors for Hostaform® POM/Celcon® POM, basic grades and nearly all specialty products. Extensive experience in color formulation has positioned Celanese as a global leader in supplying precolor and color masterbatches to various industries ranging from automotive to appliances. A broad selection of standard colors is maintained, as well as custom color-matching and subsequent supply. Our vast color technology experience enables us to deliver superior UV-resistance and special-effect appearances (pearlescent, molded-in metallic and laser markable), while minimizing effects on product properties.

Celanese supplies colors in two primary forms: precolors of the grades themselves and pellet masterbatches (concentrates) to be used with our brands. The precolors offer the most ease-of-use

and consistency of color by allowing the customer to use the material directly without further mixing. Pellet masterbatches can be purchased to mix at the press with natural grades to achieve the desired color. This sometimes minimizes inventories when multiple colors of the same grades are involved. In general, the same color is obtained as with using precolor material, but no guarantee can be given as to the exact shade since this depends on correct mixing and process-related factors.

The nomenclature used by Celanese is described in **Tab. 1**. Also shown are some standard colors available as Hostaform® POM/Celcon® POM masterbatches.

The nomenclature includes the suggested ratio to be used in mixing the pellet masterbatches with natural grades. For example, Hostaform® POM FK 1:25 14 Black would be a masterbatch that could be used if a standard Black color is needed. The distinct

**Tab. 1**

**Color Nomenclature**

Hostaform POM® Code	Color	Celcon® POM Code
10/xxx	Black	CD
20/xxx	White/Beige	CA, CB
30/xxx	Gray	CC
40/xxx	Red	CS
50/xxx	Yellow	CL
60/xxx	Brown	CY
70/xxx	Green	CJ
80/xxx	Blue	CG
90/xxx	Metallic	Cx4xxx
14	Std Black	CD3068, CD3501
10/1570	Exterior Black	
10/5358	FDA Black	CD7068
22	Std White	
Natural	Natural	CF2001, CF3500

Note: Contact [prodinfo@celanese.com](mailto:prodinfo@celanese.com) for other standard colors such as RAL.

color number is 14 (Black), and it could be used with Hostaform® POM C 9021 Natural at a ratio of 1 part masterbatch to 25 parts of C 9021 Natural. Celcon® POM nomenclature is M90-07 CD3068K20 (Black).

It could be used with Celcon® POM M90 at a ratio of 1 part masterbatch to 20 parts of M90 Natural. Alternate ratios, such as 2:25, exist. Refer to packaging for the correct ratio to use. Melt-flow rate and toughness lower than the basic grades could be a result of the colorant. It is not available with all grades.

Celanese also maintains a palette of color options matched to various industry and regulatory standards. Hundreds of colors are available in UV-resistant grades already matched to the requirements of major automotive OEMs. Matches exist in many standard grades to requirements such as RAL and Pantone.

Standard colors and approvals (+ compliant, – non-compliant)				
RAL Code	Color	FDA <sup>1)</sup>	BfR <sup>2)</sup>	KTW <sup>3)</sup>
RAL 1003	Signal yellow	+	+	+
RAL 2010	Signal orange	+	+	+
RAL 3001	Signal red	+	+	+
RAL 4008	Signal violet	+ <sup>4)</sup>	+	+
RAL 5005	Signal blue	+	+	+
RAL 6032	Signal green	+	+	+
RAL 7004	Signal gray	+	+	+
RAL 8002	Signal brown	+	–	–
RAL 9003	Signal white	–	–	–
RAL 9040	Signal black	+	+	+

1) FDA (Food and Drug Administration USA): 21 CFR 178.3297

2) BfR (Bundesinstitut für Risikobewertung, former BgVV): Recommendation IX (Empfehlung IX) contains purity requirements of colorants for polymers

3) Resolution (AP 89/1) of the Council of Europe: Colorants for Polymers

4) With limitations, e.g., not for fatty food and article not thicker than 2 millimeters



### Hostaform® POM XAP<sup>2</sup>™ Advanced Processing

Celanese offers low-odor injection molding grades that meet automotive industry requirements for plastics used in vehicle interiors. Celanese, as a leader in developing low-emission technology, formally launched the XAP® grades in 1998.

In addition to the natural and black grades of C 2521 XAP<sup>2</sup>, C 9021 XAP<sup>2</sup>, C 13021 XAP<sup>2</sup> and C 27021 XAP<sup>2</sup>, Celanese has an exceptionally broad portfolio including many special grades based on C 9021 and C 27021.

The colors in C 9021 XAP<sup>2</sup> LS and C 27021 XAP<sup>2</sup> LS are light-stabilized, while the grades C 9021 AW XAP<sup>2</sup> LS, C 9021 SW XAP<sup>2</sup> and C 9021 TF XAP<sup>2</sup>, C 9021 M XAP<sup>2</sup>, SLIDEX 0313 XAP<sup>2</sup> and SLIDEX 0304 XAP also contain special additives to reduce the coefficient of friction, wear or noise.

All XAP<sup>2</sup> grades are tested according to the VDA 275 test on injection molded plaques and the results are available through certificates of analysis. Minimal emission values can only be achieved under optimized injection molding conditions, especially low melt temperatures. More detailed information can be provided by our technical service team.

Hostaform® POM Road Map						
CORE PRODUCTS PORTFOLIO						
	C 2521	C 9021	C 13031	C 13021	C 27021	C 52021
	M15HP	M25	M90™	M140	M270	
Low Wear	Glass Fiber Reinforced		UV-Stabilized	Impact modified	Other Specialties	
Reduced COF and Wear Rate			Standard and Custom colors Molded in MetalX™			
<b>Aggressive Wear</b> C 9021 TF, LW90FS-K, SLIDEX 0313	<b>Extremely Reinforced (26% GF)</b> C 9021 GV1/30	<b>Exterior Auto* 2500+ kJ/m<sup>2</sup></b> C 9021 LS 10/1570, C 27021 LS 10/1570 WR90Z	<b>Extreme Impact</b> XT20, XT90	<b>Media Resistant</b> Enhanced chemicals and fuels resistance grade		
<b>Reduced Wear</b> LW90, LW90-S2, LW90-F2, LW90EW, XLW90BSX, C 9021 TF5, C 9021 TF2, SLIDEX 0304	<b>Highly Reinforced (20% GF)</b> C 9021 GV1/20	<b>Interior Auto<sup>1</sup> 1200 kJ/m<sup>2</sup></b> C 9021 LS, C 27021 LS UV90Z,UV270Z LX90Z	<b>High Impact</b> S 9364	<b>Mineral and Glass Bead</b> High flatness and modulus grades		
<b>Reduced Noise</b> M140-L1, C13031 RM, C 9021 SW, SLIDEX 0313, SLIDEX 0304	<b>Reinforced (10% GF)</b> C 9021 GV1/10	<b>Industry and Window</b> M25UV, M90UV, M270UV	<b>Improved Impact</b> S 9362, S 9363	<b>Medical Technology</b> Complete portfolio		
<b>Wear + Reinforced</b> C 9021 GV1/30 GT, C 9021 GV1/20 XGM	<b>Reinforced+ UV</b> LX90GC15	<b>UV + Impact</b> S 9364 UV, S 9364 WR, S 27072 WS 10/1570	<b>ESD</b> Static dissipative grades			

\*per SAE J1960 (U.S. per AP style Auto) / Contact your Celanese Account Manager

<sup>1</sup>per SAE J1885 (U.S. per AP style Auto) / Contact your Celanese Account Manager



## Typical properties

Property	Description	MVR	MFR	Shrinkage [Normal]	Shrinkage [Parallel]	Density	Melt Point	Tensile Stress <sup>2)</sup>	Tensile Strain <sup>2)</sup>	Tensile Modulus	Flexural Modulus
Unit		cm <sup>3</sup> / 10 min	g/10 min	%	%	g/cm <sup>3</sup>	°C	MPa	%	MPa	MPa
Test method		ISO 1133	ISO 1133	ISO 294-4	ISO 294-4	ISO 1183	ISO 11357	ISO 527	ISO 527	ISO 527	ISO 178
<b>Standard Unfilled<sup>1)</sup></b>											
C 2521	Extrudable for sheet and tubes. Stiff-flowing. Injection molding of thick-walled, void-free parts	2.5	3.0	1.8	2.1	1.41	165	62 (Y)	9.0 (Y)	2600	2500
M25	Extrudable for sheet and tubes. Stiff-flowing. Injection molding of thick-walled, void-free parts	2.2	-	1.8	2.2	1.41	166	63 (Y)	12.0 (Y)	2460	2430
C 9021	Standard grade	8.0	9.0	1.8	2.0	1.41	166	64 (Y)	9.0 (Y)	2850	2700
M90	Standard grade	8.0	-	1.9	2.0	1.41	165	66 (Y)	10.0 (Y)	2760	2550
M140	Easy flowing grade for precision and thin-walled parts	12.0	-	1.7	1.8	1.41	166	65 (Y)	9.0 (Y)	2740	2640
C 13021	Easy flowing grade for precision and thin-walled parts	12.0	14.0	1.8	2.0	1.41	166	65 (Y)	9.0 (Y)	2900	2800
C 27021	Very easy flowing grade for long flow paths, complicated precision parts, thin-walled and multicavity molds	24.0	27.0	1.8	1.9	1.41	166	65 (Y)	7.5 (Y)	2900	2800
C 36021		32.0	37.0	1.8	1.9	1.41	166	68 (Y)	8.0 (Y)	2800	2800
M270		23.0	-	1.6	1.7	1.41	166	67 (Y)	8.0 (Y)	2800	2750
C 52021	Extremely easy-flowing grade for complicated, thin-walled precision parts. Permits reduced melt temperature and shorter cycle times	39.0	45.0	1.8	1.9	1.41	166	65 (Y)	7.0 (Y)	3000	2800
<b>High modulus</b>											
C 13031	Similar to C 13021 but with 10% higher strength, rigidity and hardness over the entire permissible temperature range for Hostaform® POM	12.0	14.0	1.8	2.0	1.41	170	68 (Y)	8.0 (Y)	3050	3000
M15HP	Low-flow grade for sheet and tube extrusion, and thicker wall section components (> 4 mm)	1.3	-	1.9	2.3	1.40	173	68 (Y)	16.0 (Y)	2800	1750

1) Data as of June 1, 2011. Subject to change without notice. For current data, see [www.celanese.com](http://www.celanese.com) or [www.celanese.cn](http://www.celanese.cn).

2) (Y) = Yield, (B) = Break

3) DTUL: Deflection Temperature Under Load

4) CLTE: Coefficient of Linear Thermal Expansion

Many grades are available with UV additive, as lasermarkable or in low-emission versions (XAP<sup>2</sup>™). Shrinkage is highly dependent on process conditions and part design. Values in the charts are from test specimens and should only be used as a rough guide. Tools should be cut steel safe so adjustments.

As part of CEM global market support, the Celcon® POM and Hostaform® POM unfilled grades have been carefully formulated and manufactured to provide similar physical, mechanical and processing properties. CEM has experience with both products being approved against the same specification.

Notched Charpy, 23°C	Notched Charpy, -30°C	DTUL <sup>3)</sup> , 1.8 MPa	CLTE <sup>4)</sup> [Par.]	Process Equipment				Colors and Added Features Available						
				Injection Molding	Extrusion	Blow Molding	Natural	Standard Black	Standard Colors	Custom. Specific Colors	UV/LS*	WS/WR**	XAP/XAP <sup>2***</sup>	
kJ/m <sup>2</sup>	kJ/m <sup>2</sup>	°C	10 <sup>-4</sup> /°C											
ISO 179/1eA	ISO 179/1eA	ISO 75	ISO 11359-2											
8.5	7.0	101	1.1	+	+	+	+	+	+	+	+	+		+
9.1	—	94	1.2				+	+	+	+	+			
6.5	6.0	104	1.1	+		+	+	+	+	+	+	+	+	+
6.0	6.0	101	1.2				+	+	+	+	+	+		+
6.0	—	102	1.0				+	+	+	+	+			
6.5	6.0	106	1.1	+			+	+	+	+	+	+		+
5.5	5.5	106	1.1	+			+	+	+	+	+	+		+
5.0	—	103	1.1	+			+							
5.2	—	103	1.2				+	+	+	+	+	+		
5.0	5.0	106	1.1	+			+	+	+	+	+	+		+
6.7	6.0	107	1.1	+		+	+	+	+	+	+	+		+
11.0	8.5	101	1.2	+	+	+	+							

\* UV resistant  
\*\*Exterior Weatherable  
\*\*\* Low Emission  
Contact your Celanese Account Manager for details

Property	Description	MVR	MFR	Shrinkage [Normal]	Shrinkage [Parallel]	Density	Melt Point	Tensile Stress <sup>2)</sup>	Tensile Strain <sup>2)</sup>	Tensile Modulus	Flexural Modulus
Unit		cm <sup>3</sup> / 10 min	g/10 min	%	%	g/cm <sup>3</sup>	°C	MPa	%	MPa	MPa
Test method		ISO 1133	ISO 1133	ISO 294-4	ISO 294-4	ISO 1183	ISO 11357	ISO 527	ISO 527	ISO 527	ISO 178
<b>Advanced Extrusion</b>											
M10AE	High-viscosity, low-flow, extrusion grade for sheet, tubes and profiles. Not recommended for injection molding	0.9	–	–	–	1.41	167	65 (Y)	9.0 (Y)	2900	2600
M25AE	High-viscosity extrusion grade for sheet, round bars and hollow profiles. Properties similar to C 2521	2.5	–	–	–	1.41	163	60 (Y)	9.5 (Y)	2400	2400
M30AE	High-viscosity, extrusion grade for sheet, round bars, and hollow profiles. Properties similar to C 2521.	2.8	–	–	–	1.41	162	60 (Y)	9.5 (Y)	2500	2500
<b>Toughened</b>											
S 27063	Easy-flowing, elastomer-containing grade based on C 27021, higher impact strength and slightly lower hardness and rigidity than the basic grade	20.0	23.0	1.8	1.9	1.39	166	54 (Y)	9.0 (Y)	2200	2100
S 27064	Easy-flowing grade similar to S 27063, increased toughness	18.0	20.5	1.7	1.8	1.37	166	44 (Y)	10.0 (Y)	1700	1700
S 9362	Elastomer-containing grade, improved weld line and impact strength, slightly lower hardness and rigidity, for parts requiring high impact energy absorption	6.5	7.0	1.8	1.9	1.39	166	55 (Y)	10.0 (Y)	2300	2200
S 9363	Similar to S 9362 but with higher elastomer content and even higher toughness level	5.5	6.0	1.6	1.8	1.38	166	50 (Y)	12.0 (Y)	2000	2000
S 9364	Higher elastomer content than S 9363, even higher toughness level	4.0	4.5	1.5	1.6	1.37	166	43 (Y)	16.0 (Y)	1650	1550

1) Data as of June 1, 2011. Subject to change without notice. For current data, see [www.celanese.com](http://www.celanese.com) or [www.celanese.cn](http://www.celanese.cn).

2) (Y) = Yield, (B) = Break

3) DTUL: Deflection Temperature Under Load

4) CLTE: Coefficient of Linear Thermal Expansion

Many grades are available with UV additive, as lasermarkable or in low-emission versions (XAP<sup>2</sup>™). Shrinkage is highly dependent on process conditions and part design. Values in the charts are from test specimens and should only be used as a rough guide. Tools should be cut steel safe so adjustments.

As part of CEM global market support, the Celcon<sup>®</sup> POM and Hostaform<sup>®</sup> POM unfilled grades have been carefully formulated and manufactured to provide similar physical, mechanical and processing properties. CEM has experience with both products being approved against the same specification.

Notched Charpy, 23°C	Notched Charpy, -30°C	DTUL <sup>3)</sup> , 1.8 MPa	CLTE <sup>4)</sup> [Par.]	Process Equipment					Colors and Added Features Available				
				Injection Molding	Extrusion	Blow Molding	Natural	Standard Black	Standard Colors	Custom. Specific Colors	UV/LS*	WS/WR**	XAP/XAP <sup>2***</sup>
kJ/m <sup>2</sup>	kJ/m <sup>2</sup>	°C	10 <sup>-4</sup> /°C										
ISO 179/1eA	ISO 179/1eA	ISO 75	ISO 11359-2										
10.0	8.0	97	1.3	①	+	+	+	+					
8.5	-	91	1.1	①	+	+	+	+					
9	7	96	1.1	①	+	+	+	+					
9.0	6.0	84	1.2	+			+	+	+	+	+	①	+
11.0	6.0	77	1.3	+			+	+	+	+	+	①	+
10.0	6.0	87	1.1	+	+	+	+	+					+
13.0	8.0	84	1.1	+	+	+	+	+				①	+
21.0	11.0	75	1.2	+	+	+	+	+				①	+

\* UV resistant

\*\* Exterior Weatherable

\*\*\* Low Emission

① Contact your Celanese Account Manager for details

Property	Description	MVR	MFR	Shrinkage [Normal]	Shrinkage [Parallel]	Density	Melt Point	Tensile Stress <sup>2)</sup>	Tensile Strain <sup>2)</sup>	Tensile Modulus	Flexural Modulus
Unit		cm <sup>3</sup> / 10 min	g/10 min	%	%	g/cm <sup>3</sup>	°C	MPa	%	MPa	MPa
Test method		ISO 1133	ISO 1133	ISO 294-4	ISO 294-4	ISO 1183	ISO 11357	ISO 527	ISO 527	ISO 527	ISO 178
<b>Toughness</b>											
S 9243 XAP <sup>2TM</sup>	Good low-temperature impact strength and low emission. For parts requiring high-impact energy absorption and excellent weld strength	4.0	4.5	1.8	1.9	1.33	166	44 (Y)	9.0 (Y)	1950	1850
S 9244 XAP <sup>2TM</sup>	Similar to S 9243 XAP <sup>2</sup> , higher toughness level, flow properties similar to S 9364	1.4	1.6	1.6	1.7	1.26	166	33 (Y)	7.0 (Y)	1450	1450
S 27072 WS 10/1570	Easy-flowing grade similar to S 27063, UV-stabilized for exterior applications	21.0	24.5	1.9	1.8	1.39	166	46 (Y)	8.0 (Y)	2000	2100
<b>Extreme Toughness</b>											
XT20	Exceptional impact strength and flexibility over standard S 93XX and S 92XX impact-modified acetal grades	1.0	1.1	1.6	1.8	1.33	166	35 (Y)	25.0 (Y)	1200	1100
XT90	Lower viscosity grade with exceptional impact strength and flexibility over standard S 93XX and S 92XX impact-modified acetal grades	2.0	2.0	1.6	1.8	1.32	166	30 (Y)	30.0 (Y)	950	950
<b>Low Permeation Toughness</b>											
S9364 LPB	Improved toughness, low-permeation blow molding grade	0.6		1.37			166	43 (Y)	16 (Y)	1650	1550
S9364 LPI	Improved toughness, low-permeation injection molding grade	2.8		1.37			166	45 (Y)	14 (Y)	1700	1600

1) Data as of June 1, 2011. Subject to change without notice. For current data, see [www.celanese.com](http://www.celanese.com) or [www.celanese.cn](http://www.celanese.cn).

2) (Y) = Yield, (B) = Break

3) DTUL: Deflection Temperature Under Load

4) CLTE: Coefficient of Linear Thermal Expansion

Many grades are available with UV additive, as lasermarkable or in low-emission versions (XAP<sup>2TM</sup>). Shrinkage is highly dependent on process conditions and part design. Values in the charts are from test specimens and should only be used as a rough guide. Tools should be cut steel safe so adjustments.

As part of CEM global market support, the Celcon<sup>®</sup> POM and Hostaform<sup>®</sup> POM unfilled grades have been carefully formulated and manufactured to provide similar physical, mechanical and processing properties. CEM has experience with both products being approved against the same specification.

Notched Charpy, 23°C	Notched Charpy, -30°C	DTUL <sup>3)</sup> , 1.8 MPa	CLTE <sup>4)</sup> [Par.]	Process Equipment					Colors and Added Features Available				
				Injection Molding	Extrusion	Blow Molding	Natural	Standard Black	Standard Colors	Custom. Specific Colors	UV/LS*	WS/WR**	XAP/XAP <sup>2***</sup>
kJ/m <sup>2</sup>	kJ/m <sup>2</sup>	°C	10 <sup>-4</sup> /°C										
ISO 179/1eA	ISO 179/1eA	ISO 75	ISO 11359-2										
15.0	9.0	75	1.2	+	+	+	+	+					+
18.0	12.0	68	1.3	+	+	+	+	+					+
11.0	8.0	84	1.2	+					+				+
100.0	15.0	64	1.2	+	+	+	+	+					
100.0	15.0	60	1.0	+	+	+	+	+					
21	11	75	1.2	+	+	+	+		①				
18	10	75	1.2	+	+		+		①				

\* UV resistant

\*\* Exterior Weatherable

\*\*\* Low Emission

① Contact your Celanese Account Manager for details

Property	Description	MVR	MFR	Shrinkage [Normal]	Shrinkage [Parallel]	Density	Melt Point	Tensile Stress <sup>2)</sup>	Tensile Strain <sup>2)</sup>	Tensile Modulus	Flexural Modulus
Unit		cm <sup>3</sup> /10 min	g/10 min	%	%	g/cm <sup>3</sup>	°C	MPa	%	MPa	MPa
Test method		ISO 1133	ISO 1133	ISO 294-4	ISO 294-4	ISO 1183	ISO 11357	ISO 527	ISO 527	ISO 527	ISO 178
<b>Glass fiber reinforced [increased rigidity and hardness]</b>											
C 9021 GV1/10	Reinforced for parts requiring increased rigidity and hardness	n/a	n/a			1.48	166	90 (B)	4.0 (B)	4800	4500
C 9021 GV1/20	Reinforced for parts requiring high rigidity and hardness	n/a	n/a			1.57	166	120 (B)	3.0 (B)	7200	6900
C 9021 GV1/30	Reinforced for parts requiring very high strength and rigidity and increased hardness	n/a	n/a			1.60	166	135 (B)	2.5 (B)	9200	7800
GC25TF	Improved stiffness, high-strength and fuel-resistant for thin-walled parts	n/a	n/a			1.58	165	120 (B)	2.0 (B)	8720	8710
<b>Extreme Glass Coupled</b>											
XGC10	Superior mechanics vs. C9021 GV1/10	n/a	n/a			1.48	166	100 (B)	4.9 (B)	4900	4800
XGC25	Superior mechanics vs. C9021 GV1/30	n/a	n/a			1.59	166	150 (B)	3.5 (B)	9200	8300
XGC25-LW01	Tribology modified superior mechanics vs. C9021 GV1/30 GT	n/a	n/a			1.52	166	125 (B)	3.1 (B)	8200	8000
XGC15-LW01	Tribology modified, extremely high abrasion-resistance	n/a	n/a								
<b>Low warp</b>											
MC90	Reduced warpage, general purpose grade	n/a	n/a	1.6	1.9	1.48	165	57 (Y)	8.0 (Y)	3000	2850
MC270	Reduced warpage, high flow	n/a	n/a	1.6	1.9	1.48	165	57 (Y)	7.0 (Y)	3150	3100
MC90-HM	Reduced warpage, high modulus	n/a	n/a	1.3	1.5	1.57	165	45 (Y)	6.0 (Y)	3550	3500
MC270-HM	Reduced warpage, high modulus, high flow	n/a	n/a	1.3	1.5	1.57	165	45 (Y)	5.0 (Y)	3750	3700

1) Data as of June 1, 2011. Subject to change without notice. For current data, see [www.celanese.com](http://www.celanese.com) or [www.celanese.cn](http://www.celanese.cn)

2) (Y) = Yield, (B) = Break

3) DTUL: Deflection Temperature Under Load

4) CLTE: Coefficient of Linear Thermal Expansion

5) For further information on the available low-wear grades, please refer to the Slip/wear properties chapter in our brochure

Many grades are available with UV additive, as lasermarkable or in low-emission versions (XAP<sup>2TM</sup>). Shrinkage is highly dependent on process conditions and part design. Values in the charts are from test specimens and should only be used as a rough guide. Tools should be cut steel safe so adjustments.

As part of CEM global market support, the Celcon<sup>®</sup> POM and Hostaform<sup>®</sup> POM unfilled grades have been carefully formulated and manufactured to provide similar physical, mechanical and processing properties. CEM has experience with both products being approved against the same specification.

Notched Charpy, 23°C	Notched Charpy, -30°C	DTUL <sup>3)</sup> , 1.8 MPa	CLTE <sup>4)</sup> [Par.]	Process Equipment				Colors and Added Features Available				
				Injection Molding	Extrusion	Blow Molding	Natural	Standard Black	Standard Colors	Custom. Specific Colors	UV/LS*	WS/WR**
kJ/m <sup>2</sup>	kJ/m <sup>2</sup>	°C	10 <sup>-4</sup> /°C									
ISO 179/1eA	ISO 179/1eA	ISO 75	ISO 11359-2									
6.5	6.5	154	0.8	+			+	+				
8.0	8.0	159	0.5	+			+	+				
8.0	8.0	160	0.4	+			+	+				
6.4	-	162	0.3	+			+					
8		154		+	+		+	①				①
12.5				+	+		+	①				①
12		160		+	+		+	①				①
				+	+		+	①				①
6.8	5.5	97	1.0	+	+		+	+				
5.4	4.5	101	1.0	+	+		+	+				
6.3	4.9	103	0.6	+	+		+	+				
4.8	3.5	105	0.6	+	+		+	+				

\* UV resistant  
\*\* Exterior Weatherable  
\*\*\* Low Emission

① Contact your Celanese Account Manager for details

Property	Description	MVR	MFR	Shrinkage (Normal)	Shrinkage (Parallel)	Density	Melt Point	Tensile Stress <sup>2)</sup>	Tensile Strain <sup>2)</sup>	Tensile Modulus	Flexural Modulus
Unit		cm <sup>3</sup> /10 min	g/10 min	%	%	g/cm <sup>3</sup>	°C	MPa	%	MPa	MPa
Test method		ISO 1133	ISO 1133	ISO 294-4	ISO 294-4	ISO 1183	ISO 11357	ISO 527	ISO 527	ISO 527	ISO 178
<b>Low warp</b>											
C 9021 GV3/10	Reinforced for low-warp page parts requiring increased rigidity and hardness	9.0	11.2	-	-	1.47	166	52 (Y)	7.5 (Y)	3100	3000
C 9021 GV3/20	Reinforced for low-warp page parts requiring higher rigidity and hardness	8.5	11.1	-	-	1.53	166	46 (Y)	6.5 (Y)	3400	3200
C 9021 GV3/30	Reinforced for low-warp page, dimensionally stable parts requiring even higher rigidity and hardness	7.5	10.4	-	-	1.59	166	38 (Y)	6.0 (Y)	3900	3500
<b>Low wear<sup>5)</sup></b>											
SLIDEX 0313 XAP <sup>2)</sup>	Based on C13021 modified with special additive	13		1.65	2	1.4	170	60 (Y)	11.0 (Y)	2700	2550
SLIDEX 0304 XAP <sup>2)</sup>	Based on C13021 modified with special additive	26		1.75	1.85	1.4	166	56 (Y)	8.0 (Y)	2600	2350
LW90-S2	Similar to C 9021, modified with silicone oil to improve slip and wear properties	8.4	9.7	1.8	1.9	1.38	166	56 (Y)	10.0 (Y)	2500	2400
LW90-F2	Low PTFE loading, for sliding combinations with very low coefficient of friction (maintenance-free bearings)	8.0	9.0	1.9	2.3	1.41	166	63 (Y)	9.0 (Y)	2650	2600
C 9021 GV1/20 XGM	Based on C 9021 GV1/20, modified with PTFE, high stiffness with good slip and wear characteristics	n/a	n/a	-	-	1.57	166	100 (B)	2.5 (B)	7700	7400
C 9021 GV1/30 GT	Based on C 9021 GV1/30, modified with UHMWPE, good sliding combinations, wear similar to C 9021	n/a	n/a	-	-	1.54	166	110 (B)	2.5 (B)	8700	8400
C 9021 TF5	Moderate PTFE loading, for sliding combinations with very low coefficient of friction (maintenance-free bearings)	8.5	9.5	-	-	1.44	166	58 (Y)	9.0 (Y)	2600	-
C 9021 TF	High PTFE loading, sliding combinations with high load, high cycle applications	6.0	7.0	1.7	2.0	1.51	166	48 (Y)	7.0 (Y)	2500	2400

1) Data as of June 1, 2011. Subject to change without notice. For current data, see [www.celanese.com](http://www.celanese.com) or [www.celanese.cn](http://www.celanese.cn).

2) (Y) = Yield, (B) = Break

3) DTUL: Deflection Temperature Under Load

4) CLTE: Coefficient of Linear Thermal Expansion

5) For further information on the available low-wear grades, please refer to the Slip/wear properties chapter in our brochure

Many grades are available with UV additive, as lasermarkable or in low-emission versions (XAP<sup>2</sup>™). Shrinkage is highly dependent on process conditions and part design. Values in the charts are from test specimens and should only be used as a rough guide. Tools should be cut steel safe so adjustments.

As part of CEM global market support, the Celcon<sup>®</sup> POM and Hostaform<sup>®</sup> POM unfilled grades have been carefully formulated and manufactured to provide similar physical, mechanical and processing properties. CEM has experience with both products being approved against the same specification.

Notched Charpy, 23°C	Notched Charpy, -30°C	DTUL <sup>3)</sup> , 1.8 MPa	CLTE <sup>4)</sup> (Par.)	Process Equipment			Colors and Added Features Available							
				Injection Molding	Extrusion	Blow Molding	Natural	Standard Black	Standard Colors	Custom. Specific Colors	UV/LS*	WS/WR**	XAP/XAP <sup>2</sup> ***	
ISO 179/1eA	ISO 179/1eA	ISO 75	ISO 11359-2											
4.0	4.0	108	1.1	+	+		+	+						
3.5	3.5	110	1.0	+	+		+	+						
3.0	3.0	112	0.9	+	+	+	+	+						
6.0	6.0	93	1.3	+	+		+							
5.5	5.5	90	1.4	+	+		+							
7.0	4.5	94	1.1	+	+		+							
5.0	-	98	1.0	+	+		+	+						
5.5	5.5	-	0.3	+										+
5.5	5.5	159	0.3	+	+		+	+						
5.2	-	105	-	+	+		+							
4.0	4.0	98	1.1	+	+		+							+

\* UV resistant

\*\*Exterior Weatherable

\*\*\* Low Emission

📞 Contact your Celanese Account Manager for details

Property	Description	MVR	MFR	Shrinkage (Normal)	Shrinkage (Parallel)	Density	Melt Point	Tensile Stress <sup>2)</sup>	Tensile Strain <sup>2)</sup>	Tensile Modulus	Flexural Modulus
Unit		cm <sup>3</sup> /10 min	g/10 min	%	%	g/cm <sup>3</sup>	°C	MPa	%	MPa	MPa
Test method		ISO 1133	ISO 1133	ISO 294-4	ISO 294-4	ISO 1183	ISO 11357	ISO 527	ISO 527	ISO 527	ISO 178
<b>Low wear<sup>5)</sup></b>											
C 9021 M		8.5	-	1.8	2.0	1.42	166	65 (Y)	9.0 (Y)	2800	2700
C 9021 K	Modified with special chalk, good wear properties for unlubricated for once-only lubricated sliding parts	7.5	8.5	1.8	2.0	1.44	166	60 (Y)	8.0 (Y)	3000	2900
C 9021AW	Low wear, low noise, for low-load, high-speed applications	8.0	9.0	1.9	2.1	1.38	166	58 (Y)	8.0 (Y)	2600	-
C 9021 SW	Modified with noise-deadening and wear-protecting additives. Additives also reduce acoustic vibrations in the finished parts	6.5	7.5	1.8	2.0	1.42	166	53 (Y)	7.0 (Y)	2850	-
C 9021 G	Reinforced with GUR <sup>®</sup> PE-UHMW, for parts under abrasion stress	5.5	6.5	1.8	2.3	1.34	166	45 (Y)	9.0 (Y)	2300	2100
LW15EWX	Similar to M15HP but modified with special waxes, good sliding combinations under pressure	2.5	-	-	-	1.40	173	63 (Y)	19.0 (Y)	2650	-
LW90EWX	For wear resistance against other thermoplastics	9.5	10.5	-	-	1.40	166	61 (Y)	8.0 (Y)	2800	-
LW90BSX	Modified with silicone, good sliding combinations POM/POM	7.0	-	-	-	1.37	166	51 (Y)	15.0 (Y)	2350	2250
C 13021 RM	Easy-flowing grade similar to C 13021, good low-friction properties, e.g., for smooth-running zip fasteners (zippers)	12.5	14.5	1.8	2.0	1.41	166	65 (Y)	9.0 (Y)	2900	2800
<b>Laser markable grades</b>											
LM90	General purpose, laser markable	8.0	9.0	1.9	2.0	1.41	167	64 (Y)	9.0 (Y)	2750	2700
LM90Z	Standard flow, UV resistant, laser markable	8.0	9.0	1.9	2.0	1.41	167	63 (Y)	9.0 (Y)	2700	2670

1) Data as of June 1, 2011. Subject to change without notice. For current data, see [www.celanese.com](http://www.celanese.com) or [www.celanese.cn](http://www.celanese.cn).

2) (Y) = Yield, (B) = Break

3) DTUL: Deflection Temperature Under Load

4) CLTE: Coefficient of Linear Thermal Expansion

Many grades are available with UV additive, as lasermarkable or in low emission versions (XAP<sup>2™</sup>). Shrinkage is highly dependent on process conditions and part design. Values in the charts are from test specimens and should only be used as a rough guide. Tools should be cut steel safe so adjustments.

As part of CEM global market support, the Celcon<sup>®</sup> and Hostaform<sup>®</sup> unfilled grades have been carefully formulated and manufactured to provide similar physical, mechanical and processing properties. CEM has experience with both products being approved against the same specification.

Notched Charpy, 23°C	Notched Charpy, -30°C	DTUL <sup>3)</sup> , 1.8 MPa	CLTE <sup>4)</sup> (Par.)	Process Equipment			Colors and Added Features Available						
				Injection Molding	Extrusion	Blow Molding	Natural	Standard Black	Standard Colors	Custom. Specific Colors	UV/LS*	WS/WR**	XAP/XAP <sup>2***</sup>
kJ/m <sup>2</sup>	kJ/m <sup>2</sup>	°C	10 <sup>-4</sup> /°C										
ISO 179/1eA	ISO 179/1eA	ISO 75	ISO 11359-2										
6.0	-	100	1.1										
5.0	5.0	100	1.1	+	+		+						
5.0	5.0	88	1.1	+	+		+	+	+				+
4.0	4.0	80	1.2	+	+		+	+					+
3.5	3.0	88	1.2	+	+		+	+					
14.0	11.0	93	-	+	+		+						
6.5	11.0	92	-	+			+	+					
5.5	-	90	-	+			+	+					
6.5	6.0	102	1.1	+			+	+					
5.5	-	98	1.0	+									+
4.7	-	95	1.0	+								+	+

\* UV resistant

\*\*Exterior Weatherable

\*\*\* Low Emission

📞 Contact your Celanese Account Manager for details

Property	Description	MVR	MFR	Shrinkage [Normal]	Shrinkage [Parallel]	Density	Melt Point	Tensile Stress <sup>2)</sup>	Tensile Strain <sup>2)</sup>	Tensile Modulus	Flexural Modulus
Unit		cm <sup>3</sup> / 10 min	g/10 min	%	%	g/cm <sup>3</sup>	°C	MPa	%	MPa	MPa
Test method		ISO 1133	ISO 1133	ISO 294-4	ISO 294-4	ISO 1183	ISO 11357	ISO 527	ISO 527	ISO 527	ISO 178
<b>MetaLX™ (metallic appearance effect)</b>											
LX90	Based on C 9021, metallic appearance effect	8.0	9.0			1.43	166	56 (Y)	10.0 (Y)	2700	2700
LX90Z	Based on C 9021, UV-stabilized, metallic appearance effect	8.0	9.0			1.43	166	54 (Y)	10.0 (Y)	2800	2850
LX90GC15	Based on C 9021, metallic appearance effect, reinforced with 15 % glass for parts requiring increased rigidity and hardness	n/a	n/a			1.50	166	75 (B)	4.0 (B)	5500	5200
<b>Low gloss</b>											
UV140LG		13.0	-	1.5	1.6	1.33	165	41 (Y)	10.0 (Y)	1950	1890
UV resistant grades – Interior automotive: SAEJ 1885 for U.S. Auto											
UV25Z	Interior automotive UV	2.2	2.5	1.7	2.2	1.41	166	63 (Y)	11.0 (Y)	2500	2420
UV90Z	Interior automotive UV	8.0	9.0	1.7	1.9	1.41	165	64 (Y)	9.0 (Y)	2700	2470
UV270Z	Interior automotive UV	23.0	25.0	1.6	1.7	1.41	167	64 (Y)	8.0 (Y)	2700	2750
UV resistant grades – Interior automotive: PV1303 for EU Auto											
C 2521 LS	Interior automotive UV	2.5	3.0	1.8	2.1	1.41	165	62 (Y)	9.0 (Y)	2600	2500
C 9021 LS	Interior automotive UV	8.0	9.0	1.8	2.0	1.41	166	64 (Y)	9.0 (Y)	2850	2700
C 27021 LS	Interior automotive UV	24.0	27.0	1.8	1.9	1.41	166	65 (Y)	7.5 (Y)	2900	2800
<b>UV resistant toughened</b>											
SXT90Z-01	Toughened, UV stabilized grade for automotive interiors and other UV applications	7				1.38	166	49 (Y)	12 (Y)	1900	
SXT90Z-02	Higher elastomer content than SXT9Z-01, UV stabilized grade for automotive interior and other UV applications	4				1.36	166	41 (Y)	13 (Y)	1500	
<b>UV resistant grades – weatherable</b>											
WR90Z	Non automotive UV	8.0	9.0	1.6	1.7	1.41	166	63 (Y)	8.0 (Y)	2650	2550
C 9021 LS 10/1570	Non automotive UV	8.5	9.5	1.8	2.0	1.41	166	64 (Y)	9.0 (Y)	2850	2700

1) Data as of June 1, 2011. Subject to change without notice. For current data, see [www.celanese.com](http://www.celanese.com) or [www.celanese.cn](http://www.celanese.cn).

2) (Y) = Yield, (B) = Break

3) DTUL: Deflection Temperature Under Load

4) CLTE: Coefficient of Linear Thermal Expansion

Many grades are available with UV additive, as lasermarkable or in low-emission versions [XAP<sup>2</sup>™]. Shrinkage is highly dependent on process conditions and part design. Values in the charts are from test specimens and should only be used as a rough guide. Tools should be cut steel safe so adjustments.

As part of CEM global market support, the Celcon® POM and Hostaform® POM unfilled grades have been carefully formulated and manufactured to provide similar physical, mechanical and processing properties. CEM has experience with both products being approved against the same specification.

Notched Charpy, 23°C	Notched Charpy, -30°C	DTUL <sup>3)</sup> , 1.8 MPa	CLTE <sup>4)</sup> [Par.]	Process Equipment				Colors and Added Features Available				
				Injection Molding	Extrusion	Blow Molding	Natural	Standard Black	Standard Colors	Custom. Specific Colors	UV/LS*	WS/WR**
kJ/m <sup>2</sup>	kJ/m <sup>2</sup>	°C	10 <sup>-4</sup> /°C									
ISO 179/1eA	ISO 179/1eA	ISO 75	ISO 11359-2									
5.0	4.0	88	-	+	+						+	
4.0	4.0	88	0.9	+	+						+	+
4.0	4.0	155	0.5	+							+	
3.1	-	80	1.3					+	+	+	+	+
8.0	-	90	1.1	+	+	+	+	+	+	+	+	
6.0	5.5	91	1.1	+			+	+	+	+	+	+
4.7	4.2	90	1.1	+			+	+	+	+	+	+
8.5	7.0	101	1.1	+	+	+	+	+	+	+	+	+
6.5	6.0	104	1.1	+			+	+	+	+	+	+
5.5	5.5	106	1.1	+			+	+	+	+	+	+
11	7			+			+	+	+	+	+	+
13	8			+			+	+	+	+	+	+
5.5	5.5	95	1.0	+	+						+	+
6.5	6.0	104	1.1	+	+			+				+

\* UV resistant

\*\*Exterior Weatherable

\*\*\* Low Emission

📞 Contact your Celanese Account Manager for details

Property	Description	MVR	MFR	Shrinkage [Normal]	Shrinkage [Parallel]	Density	Melt Point	Tensile Stress <sup>2)</sup>	Tensile Strain <sup>2)</sup>	Tensile Modulus	Flexural Modulus
Unit		cm <sup>3</sup> / 10 min	g/10 min	%	%	g/cm <sup>3</sup>	°C	MPa	%	MPa	MPa
Test method		ISO 1133	ISO 1133	ISO 294-4	ISO 294-4	ISO 1183	ISO 11357	ISO 527	ISO 527	ISO 527	ISO 178
<b>UV resistant grades – General industry</b>											
M25UV	Improved toughness, improved UV resistance for industry	2.2	2.5	1.8	2.2	1.41	166	62 (Y)	12.0 (Y)	2500	2400
M90UV	General purpose, improved for industry	8.0	9.0	1.7	1.9	1.41	165	65 (Y)	10.0 (Y)	2600	2550
M270UV	Improved for industry	23.0	27.0	1.6	1.7	1.41	167	66 (Y)	8.0 (Y)	2800	2750
<b>ESD grades</b>											
EC140XF	Electroconductive, superior chemical resistant to aggressive environments, e.g., automotive fuel systems requiring electroconductive properties	4.0	4.5	1.9	2.1	1.42	166	51 (Y)	4.7 (Y)	2700	2650
CF802	Modified with 6% stainless steel fibers, fuel compatible ESD electrostatic dissipative grade	n/a	n/a	1.6	1.7	1.47	167	60 (Y)	10.0 (Y)	3100	3100
EC140CF10	Modified with 10% carbon fiber, electrostatic dissipative grade (10·5 to 10·8 ohms), fuel compatible	12.0	13.0	1.0	0.8	1.42	165	70 (B)	1.5 (B)	8500	8500
EC270TX	Electroconductive/ dissipative grade with improved impact, not suitable for fuel applications	1.5	1.7	-	-	1.38	166	14 (Y)	11.0 (Y)	1950	-
C 27021 AS		25.0	28.0	1.8	1.9	1.41	166	62 (Y)	8.0 (Y)	2800	2700
<b>Media resistant</b>											
MR90B	Improved bleach and media resistance	8.0	9.0	2.2	2.2	1.41	166	65 (Y)	11.0 (Y)	2800	2800
MR130ACS	Improved acid, chlorine and media resistance	12.0	14.0	-	-	1.41	170	62 (Y)	11.0 (Y)	2900	-
C 13031 XF	Improved hot diesel resistant for automotive fuel systems	12.0	14.0	1.9	2.2	1.42	170	62 (Y)	11.0 (Y)	2850	2900

1) Data as of June 1, 2011. Subject to change without notice. For current data, see [www.celanese.com](http://www.celanese.com) or [www.celanese.cn](http://www.celanese.cn).

2) (Y) = Yield, (B) = Break

3) DTUL: Deflection Temperature Under Load

4) CLTE: Coefficient of Linear Thermal Expansion

Many grades are available with UV additive, as lasermarkable or in low-emission versions (XAP<sup>2TM</sup>). Shrinkage is highly dependent on process conditions and part design. Values in the charts are from test specimens and should only be used as a rough guide. Tools should be cut steel safe so adjustments.

As part of CEM global market support, the Celcon<sup>®</sup> POM and Hostaform<sup>®</sup> POM unfilled grades have been carefully formulated and manufactured to provide similar physical, mechanical and processing properties. CEM has experience with both products being approved against the same specification.

Notched Charpy, 23°C	Notched Charpy, -30°C	DTUL <sup>3)</sup> , 1.8 MPa	CLTE <sup>4)</sup> (Par.)	Process Equipment				Colors and Added Features Available					
				Injection Molding	Extrusion	Blow Molding	Natural	Standard Black	Standard Colors	Custom. Specific Colors	UV/LS*	WS/WR**	XAP/XAP <sup>2***</sup>
kJ/m <sup>2</sup>	kJ/m <sup>2</sup>	°C	10 <sup>-4</sup> /°C										
ISO 179/1eA	ISO 179/1eA	ISO 75	ISO 11359-2										
8.5	-	93	1.2	+	+	+	+					+	
6.1	-	101	1.1	+	+		+					+	
4.5	-	102	1.1	+			+					+	
4.0	3.0	91	1.0	+				+					
4.5	4.1	100	1.0	+					+				
3.2	3.2	158	0.3	+						+			
6.5	-	-	-	+							+		
5.0	4.5	100	1.1							+			
5.1	5.0	100	1.0	+	+		+	+				+	
8.0	6.0	100	0.9	+			+	+					
7.5	6.0	102	0.9	+				+	+				

\* UV resistant

\*\*Exterior Weatherable

\*\*\* Low Emission

📞 Contact your Celanese Account Manager for details

Property	Description	MVR	MFR	Shrinkage (Normal)	Shrinkage (Parallel)	Density	Melt Point	Tensile Stress <sup>2)</sup>	Tensile Strain <sup>2)</sup>	Tensile Modulus	Flexural Modulus
Unit		cm <sup>3</sup> /10 min	g/10 min	%	%	g/cm <sup>3</sup>	°C	MPa	%	MPa	MPa
Test method		ISO 1133	ISO 1133	ISO 294-4	ISO 294-4	ISO 1183	ISO 11357	ISO 527	ISO 527	ISO 527	ISO 178
<b>Medical technology (USP/Healthcare approvals)</b>											
MT2U01		2.2	2.5	2.3	2.5	1.41	165	62 (Y)	9.0 (Y)	260	2500
MT8U01	Optimum properties for healthcare market	8.0	9.0	1.8	2.0	1.41	166	64 (Y)	9.0 (Y)	2850	2700
MT8U05		8.0	9.0	1.8	2.0	1.41	166	64 (Y)	9.0 (Y)	2850	2700
MT12U01	Optimum properties for healthcare market	12.0	14.0	1.8	2.0	1.41	166	65 (Y)	9.0 (Y)	2900	2800
MT12U03	High modulus for improved toughness for healthcare market	12.0	14.0	1.8	2.0	1.41	170	70 (Y)	8.0 (Y)	3100	3000
MT24U01	Optimum properties for healthcare market	24.0	27.0	1.8	1.9	1.41	166	65 (Y)	7.5 (Y)	2900	2800
MT8F01	Low PTFE loading to enhance slip/wear characteristics for healthcare market	8.5	9.5	–	–	1.44	166	58 (Y)	9.0 (Y)	2600	–
MT8F02	High PTFE loading to enhance slip/wear characteristics for healthcare market	6.0	7.0	1.7	2.0	1.52	166	48 (Y)	7.0 (Y)	2500	2400
MT24F01	Low PTFE loading to enhance slip/wear characteristics for healthcare market	21.0	24.0	1.8	1.9	1.44	166	58 (Y)	–	2600	–
MT8R02	Modified to enhance slip characteristics for healthcare market	8.5	9.5	1.8	2.0	1.40	166	62 (Y)	9.0 (Y)	2700	–
MT12R01	Modified to enhance slip characteristics for healthcare market	12.0	14.0	1.8	2.0	1.41	166	65 (Y)	9.0 (Y)	2900	2800
MTSLIDEX1203	Standard flow with tribological modification	13		1.65	2.0	1.40	170	58 (Y)	12.0 (Y)	2650	2500
MTSLIDEX2404	Easy flow with tribological modification	25.0		1.75	1.85	1.40	166	55 (Y)	7.0 (Y)	2550	2300

1) Data as of June 1, 2011. Subject to change without notice. For current data, see [www.celanese.com](http://www.celanese.com) or [www.celanese.cn](http://www.celanese.cn).

2) (Y) = Yield, (B) = Break

3) DTUL: Deflection Temperature Under Load

4) CLTE: Coefficient of Linear Thermal Expansion

Many grades are available with UV additive, as lasermarkable or in low-emission versions (XAP<sup>2</sup>™). Shrinkage is highly dependent on process conditions and part design. Values in the charts are from test specimens and should only be used as a rough guide. Tools should be cut steel safe so adjustments.

As part of CEM global market support, the Celcon<sup>®</sup> POM and Hostaform<sup>®</sup> POM unfilled grades have been carefully formulated and manufactured to provide similar physical, mechanical and processing properties. CEM has experience with both products being approved against the same specification.

Notched Charpy, 23°C	Notched Charpy, -30°C	DTUL <sup>3)</sup> , 1.8 MPa	CLTE <sup>4)</sup> (Par.)	Process Equipment				Colors and Added Features Available					
				Injection Molding	Extrusion	Blow Molding	Natural	Standard Black	Standard Colors	Custom. Specific Colors	UV/LS*	WS/WR**	XAP/XAP <sup>2</sup> ***
kJ/m <sup>2</sup>	kJ/m <sup>2</sup>	°C	10 <sup>-4</sup> /°C										
ISO 179/1eA	ISO 179/1eA	ISO 75	ISO 11359-2										
8.5	7.0	101	1.1		+	+	+						
6.5	6.0	104	1.1	+	Ⓢ		+						
6.5	6.0	104	1.1				+						
6.0	6.0	106	1.1	+			+						
6.0	6.0	112	1.2	+			+						
5.5	5.5	106	1.1	+			+						
5.2	-	-	-	+	+		+						
4.0	4.0	98	1.1	+			+						
4.0	-	100	-	+			+						
8.0	-	82	-	+			+						
6.5	6.0	102	1.1	+			+						
6.0	6.0	93	1.3	+			+						
5.5	5.5	90	1.4	+			+						

\* UV resistant

\*\*Exterior Weatherable

\*\*\* Low Emission

Ⓢ Contact your Celanese Account Manager for details

## Further thermal and electrical properties

- ▶ Flammability in accordance with UL 94:
  - all grades: HB
- ▶ Thermal conductivity at 20 °C – according to DIN 52 612:
  - all basic grades and grades with improved sliding properties: 0.31 W/m · K
  - C 9021 GV 1/30: 0.41 W/m · K
  - S grades: 0.27 to 0.34 W/m · K.
- ▶ Specific heat at 20 °C:
  - all basic grades and grades with improved sliding properties: 1.47 kJ/kg · K
  - C 9021 GV 1/30: 1.21 kJ/kg · K.
- ▶ Volume resistivity – in accordance with IEC 60093:
  - all grades except the high-impact grades, and C 9021 ELSX, EC270TX, EC140XF:  $10^{12} \Omega \cdot m$
  - S grades:  $10^{11} \Omega \cdot m$
  - EC140CF10, EC270TX:  $10 \Omega \cdot m$
  - EC140XF:  $5 \Omega \cdot m$
- ▶ Surface resistance – in accordance with IEC 60093:
  - all grades except the high-impact grades, and C 27021 AS, EC270TX, EC140XF:  $10^{14} \Omega$
  - S grades:  $10^{13} \Omega$
  - C 27021 AS:  $10^{13} \Omega$
  - ELSX, EC270TX, EC140XF:  $10^3 \Omega$
- ▶ Comparative tracking index CTI – according to IEC 60112:
  - all grades except C 27021 AS, EC270TX, EC140XF and those colored with black 10/1570: 600
- ▶ Arc resistance – in accordance with VDE 0303 part 5:
  - all grades except the high-impact grades: L 4
- ▶ Glow wire test – in accordance with IEC 695, part 2-1:
  - all basic, glass-fiber-reinforced and glass-sphere-reinforced grades and high-impact grades: 550 °C

\*Values shown are typical. They do not represent a minimum or maximum for product specification.

## Quality Management

Meeting the quality requirements of our customers is a critical activity for Celanese. We constantly pursue and update the certifications needed for this purpose. Our quality management system has been certified to ISO 9000 standards since the early 1990s.

In 2003, on this foundation, we built a global Integrated Management System (IMS) for quality and environmental management.

Our websites [www.celanese.com](http://www.celanese.com) and [www.celanese.cn](http://www.celanese.cn) provide further information under “Quality and Certifications.” This information includes the details of business lines and facilities covered and PDF files of all current certificates of registration for download.

Certification Standards				
Standard	Application	Americas	Europe	Asia
ISO 9001	Quality management	X	X	X
ISO/TS 16949	Application of ISO 9001 for automotive	X	X	X*
ISO 14001	Environmental system management	X	X	X*
ISO/IEC 17025	Laboratory accreditation	X	X	

\* In progress



# 3 Physical Properties

This section discusses the important characteristic properties of Hostaform® POM and their dependence on temperature and time. These properties were primarily determined by standard test methods.

Descriptions of the Hostaform® POM grades and their properties are available on the Celanese homepage [www.celanese.com](http://www.celanese.com).

The Hostaform® POM basic grades cover melt-volume-flow rate range from 0.9 to 39 cm<sup>3</sup>/10 min and have a density of 1.41 g/cm<sup>3</sup>. The addition of glass or elastomer lowers the melt-flow rate; density is increased in the first case and reduced in the second. Hostaform® POM has low water absorption.

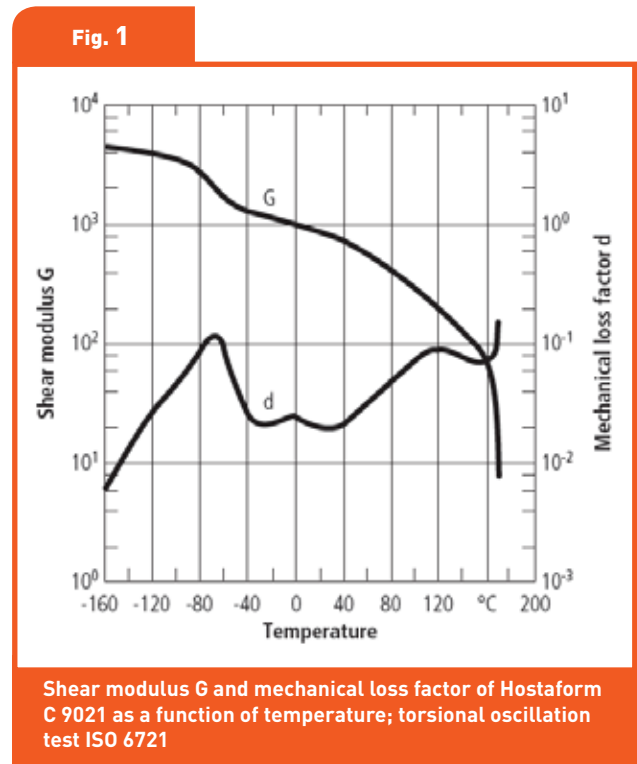
### 3.1 Mechanical properties

Determination of the properties of plastics by standard test methods yields valuable information for purposes of production control and facilitates preliminary selection of materials by the designer. However, the results of short time tests are seldom a suitable basis for the dimensioning of structural elements.

Thermoplastics are viscoelastic materials. They exhibit the property known as creep, i.e., they tend to undergo deformation with time, depending on temperature and stress. After stress removal, depending on the level and duration of stress, a molded part returns partially or completely to its original shape. The reversible deformation corresponds to the elastic portion and the permanent deformation to the plastic portion. This viscoelastic behavior must be borne in mind when designing molded parts.

From the above, it follows that the mechanical properties of a plastic are primarily dependent on three important basic parameters: time, temperature and stress. Further important influences are design, conditions of manufacture and environmental conditions. One important factor which characterizes a plastic is the dependence of shear modulus  $G$  on temperature.

The temperature dependency of the shear modulus  $G$  and the mechanical loss factor  $d$  are shown in **Fig. 1** for Hostaform® POM C 9021 and in **Fig. 2** for Hostaform® POM S 9364 (see also section 3.2 Thermal properties.)



The property values determined on test specimens by standard methods are guide values and can be used as a basis for comparing different materials. However, they have only limited applicability to finished parts. The strength of a component depends to a great extent on design and hence design strength is the criterion used to assess load-bearing capacity [14, 15].

### 3.1.1 Properties under short-term stress

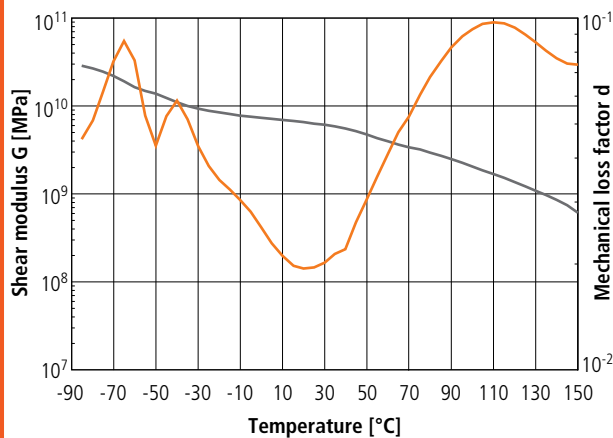
The behavior of materials under steady, short-term stress can be examined in the tensile test according to ISO 527. This test enables the yield stress, elongation at yield, ultimate tensile strength and elongation at break.

**Fig. 3** shows the yield stress of various thermoplastics as a function of temperature. It can be seen that Hostaform® POM C has considerably higher strength than the standard plastics.

Other properties measured under short-term stress are the tensile modulus and flexural modulus, both determined according to ISO 527 and ISO 178. These values provide an indication of rigidity and are used not only to characterize plastics but also for strength calculation and the design of molded parts.

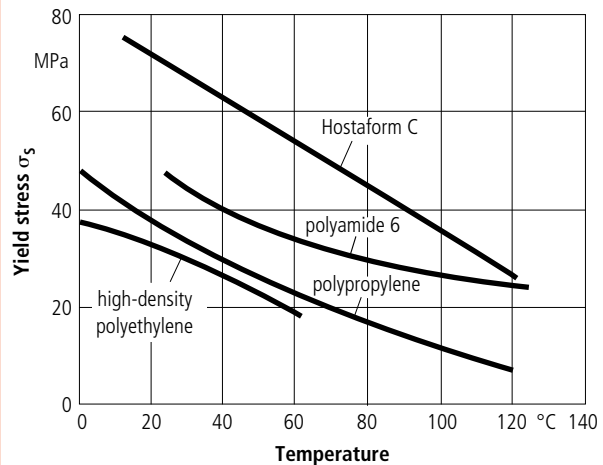
Hostaform® POM C has higher rigidity values than the standard polymers and, because of its particular spectrum of properties, is classed as an engineering plastic.

**Fig. 2**



Shear modulus G and mechanical loss factor of Hostaform S 9364 as a function of temperature; torsional oscillation test ISO 6721

**Fig. 3**



Yield stress of various thermoplastics as a function of temperature (deformation rate 12.5 mm/min, test specimen 3 with dimensions in the ratio 1:4, prepared from compression molded sheet)

### 3.1.2 Properties under long-term stress

The results of long-term tests carried out under various conditions provide the design engineer with a basis for calculation when designing components subjected to prolonged stress.

The properties of plastics under long-term tensile stress are tested by two basic methods:

- ▶ creep rupture test according to ISO 899 (deformation increase in specimen held under constant stress)

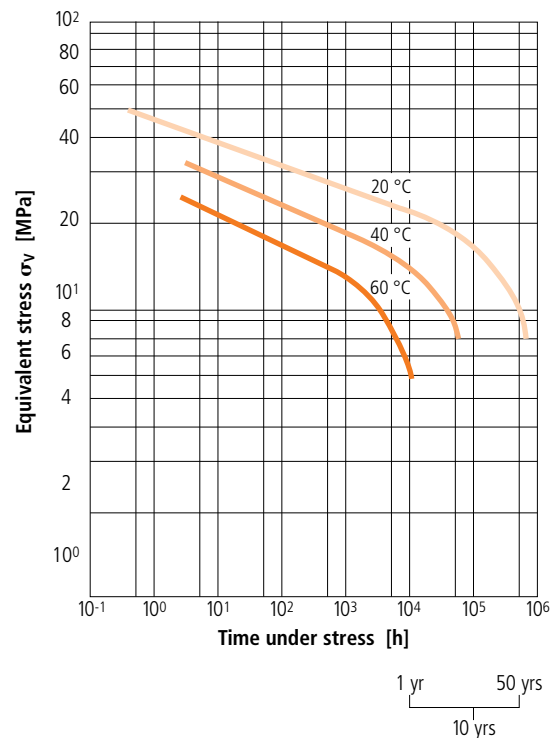
The first test gives the creep strength, i.e., the time to rupture of a test bar loaded with a specified stress under defined environmental conditions. These tests are carried out on tensile test bars (uniaxial stress condition) or on pipes (multiaxial stress condition) in air or another medium.



The strain values and creep moduli determined in the creep rupture test under tensile stress also serve as a good approximation for the values to be expected under flexural and compressive stress. To provide a certain safety margin against failure, a strain from 0.5% to 1% is usually allowed for in design calculations.

The deformation of a plastic component not only is time- and temperature- dependent but also is a function of the type of stress. Strictly speaking, separate characteristic values should be determined for each type of stress. However, for deformation 2%, the variation between the characteristic values is negligible, so that, for example, the time-dependent compression of a component under compressive stress may be calculated with sufficient accuracy using the flexural creep modulus (determined under flexural stress).

Fig. 5



Creep strength of pipes made from Hostaform C 2521 (test temperature 20 to 60 °C, water inside and outside)

The results of creep tests under uniaxial stress have only limited applicability to the multiaxial stress state.

**Fig. 5** shows the creep strength of pipes made from Hostaform® POM C 2521 under internal pressure.

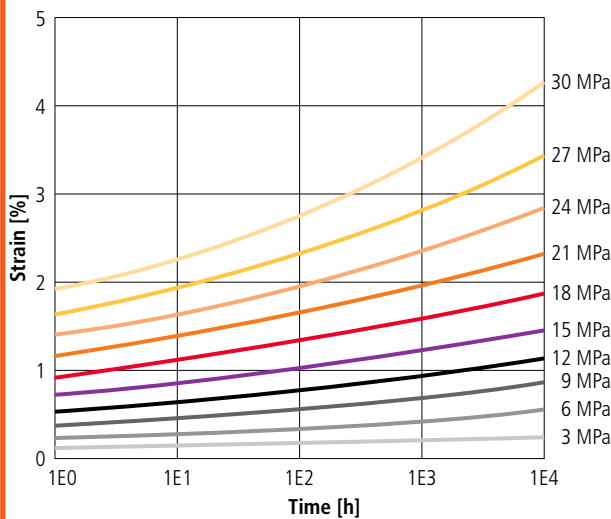
**Fig. 6** shows the creep curves (time-strain curves) determined with tensile test bars made from Hostaform® POM C 9021 for various stresses at a test temperature of 23 °C in air. By joining the endpoints of these lines, the failure curve is obtained; this represents the creep strength. For a stress of 10 MPa, for example, and a time under stress of 10 years, a strain of 1.1% is obtained.

The time-compressive stress curves for Hostaform® POM C 9021 are similar to those for time-tensile stress. By analogy with the time-strain limits, it is possible in this case to speak of time-compression limits. From **Fig. 7**, the permissible compressive

stress for a given time under stress and percentage compression may be deduced. For a period under stress of one year a permissible compression of 0.5%, the continuous compressive stress may amount to 7.5 MPa. With a permissible compression of 1%, 14 MPa would be possible.

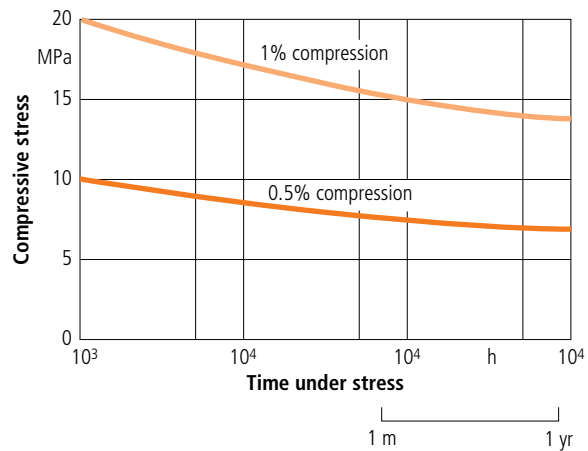
In addition to the information provided by creep tests under tensile stress or internal pressure as described above, knowledge of behavior under flexural stress is important in designing many structural components.

**Fig. 6**



Time-strain curves (creep curves) for Hostaform C 9021, measured at 23 °C (also a good approximation for the other unmodified Hostaform grades)

**Fig. 7**



Time-compressive stress curves for Hostaform C 9021, at 20 °C

**Fig. 8** shows the flexural creep modulus of Hostaform C 9021 as a function of time and temperature.

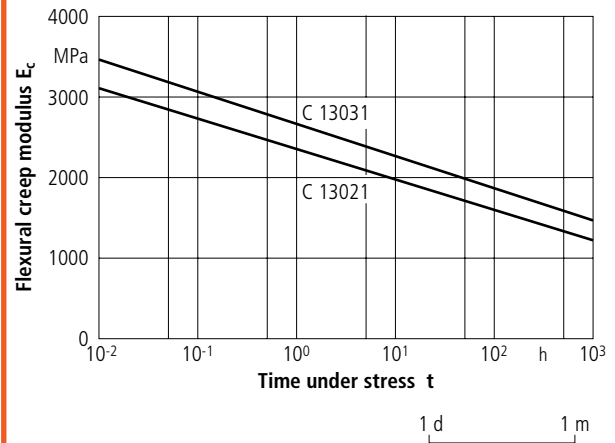
**Fig. 9** shows that the flexural creep modulus of Hostaform C 13031 is about 10 % higher than that of Hostaform C 13021 throughout the test period.

The addition of glass fibers substantially reduces creep, even in the case of rigid thermoplastics. **Fig. 10** compares the flexural creep modulus of unreinforced and of glass-fiber-reinforced Hostaform® POM.

It can be seen that the flexural creep modulus of glass-fiber-reinforced Hostaform® POM after one year's loading at 80 °C is still higher than the initial flexural creep modulus of unreinforced material at 20 °C.

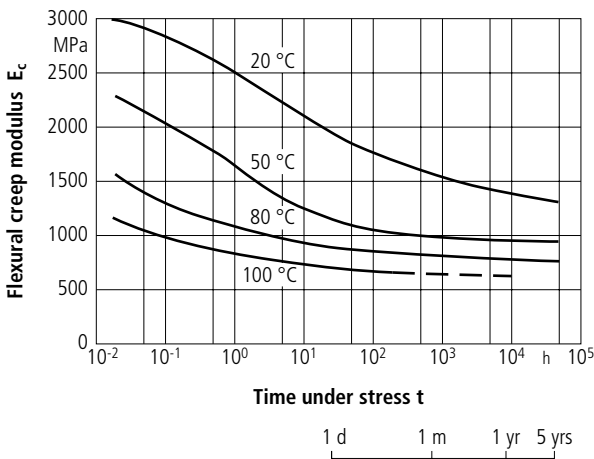
An indication of the creep behavior of the high-impact Hostaform® POM grades is given in **Figs. 12 a to 12d**. These show the time-strain curves for Hostaform S 9363, S 9364, S 9243 XAP<sup>2</sup> and S 9244 XAP<sup>2</sup> determined in the creep rupture test under tensile stress (ISO 899) at 23 °C for several stresses.

**Fig. 9**



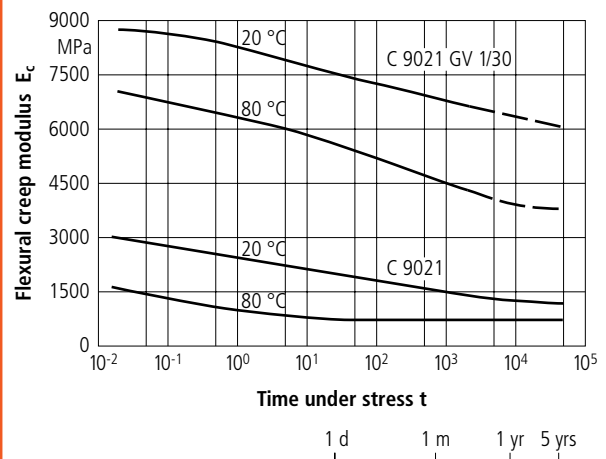
Flexural creep modulus of Hostaform C 13031 and Hostaform C 13021 (test specimen injection molded, outer-fiber stress  $s_b = 10$  MPa, test temperature 23 °C)

**Fig. 8**



Flexural creep modulus of Hostaform C 9021 at various temperatures [measured with an outer-fiber stress  $s_b = 10$  MPa]

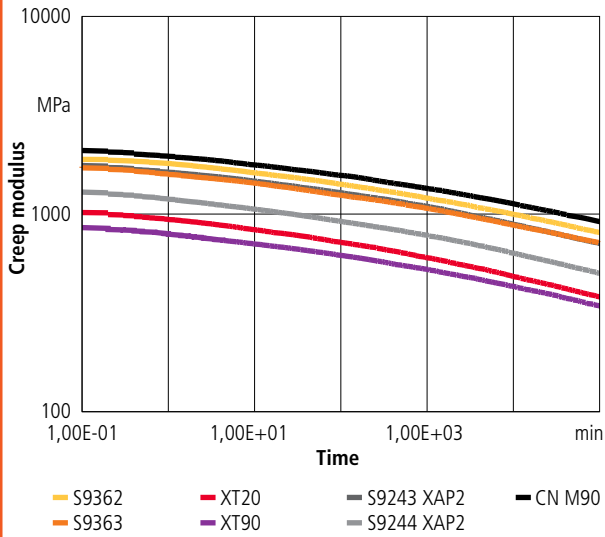
**Fig. 10**



Flexural creep modulus of Hostaform C 9021 GV 1/30 and Hostaform C 9021 (outer-fiber stress  $s_b = 10$  MPa, test temperature 20 and 80 °C)

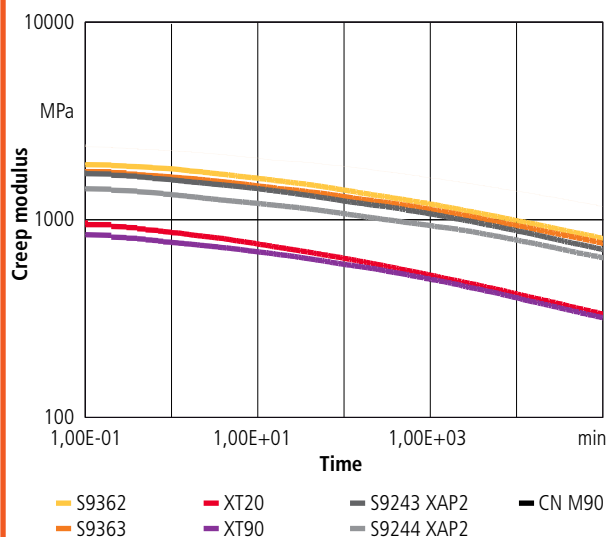


Fig. 12a



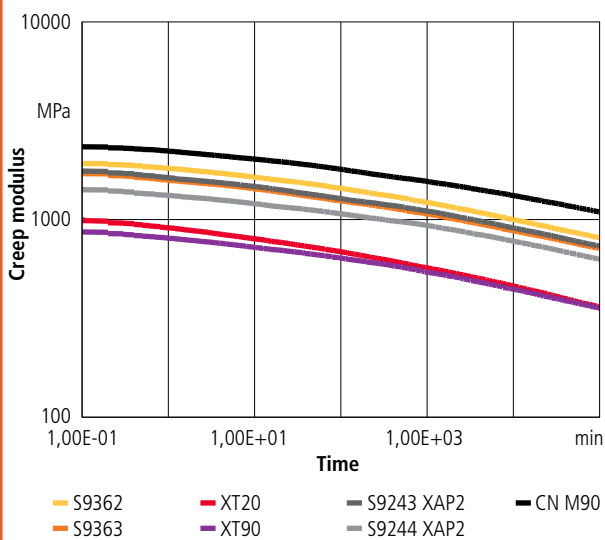
Creep Modulus vs. Time (23 °C, 5 MPa)

Fig. 12c



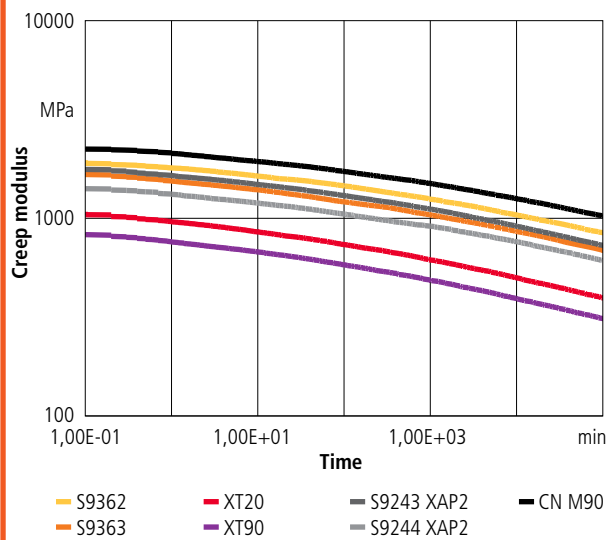
Creep Modulus vs. Time (23 °C, 15 MPa)

Fig. 12b



Creep Modulus vs. Time (23 °C, 10 MPa)

Fig. 12d



Creep Modulus vs. Time (23 °C, 20 MPa)

### 3.1.3 Properties under impact stress

The toughness of molded articles made from viscoelastic materials is very much a function of deformation rate as well as factors such as design, state of orientation, manufacturing conditions and the service environment, especially temperature. A material that exhibits relatively high extensibility at a low deformation rate, as, for example, in a conventional tensile test with deformation rates  $vD = 0.1$  to  $10\%$  per sec, may fail without elongation in a tensile impact test at deformation rates  $vD$  of, for example,  $10,000\%$  per sec, and thus appear to be a brittle material.

Like high deformation rates, low temperatures also cause a decrease in toughness.

Notches have the same effect. They create a stress concentration point at the root of the notch (which may be expressed by the notch shape factor  $\alpha_K$  [14]). This leads to a reduction in strength, particularly at a high deformation rate. Notches must be avoided if at all possible in the design of plastic parts.

Information on the behavior of plastics at high deformation rates is provided by flexural impact, drop and penetration tests.

#### 3.1.3.1 Hostaform® POM basic grades

The glass transition temperature of the Hostaform® POM base polymer (from  $-60$  to  $-65$  °C) is low compared to that of other plastics. This explains its remarkably high-impact strength even at low temperature.

The impact strength of the Hostaform® POM basic grades decreases slightly with increasing melt mass-flow-rate (= decreasing molecular weight). This relationship between molecular weight and resistance to impact stress can be discerned in all the test methods used. The stiff-flowing grades C 9021, C 2521 and M25AE are therefore suitable for the production of impact-resistant moldings, provided these have medium to large wall thickness.

The use of high-molecular-weight grades such as

C 2521 for thin-walled parts can lead to orientation of the molecular chains in the flow direction, resulting in moldings with high internal stresses and anisotropy of mechanical properties.

Easier-flowing grades give rise to less oriented, stress-free moldings with considerably higher toughness than moldings made from high-molecular-weight grades.

#### 3.1.3.2 Reinforced and filled grades

Incompatible additives have the effect of reducing toughness. This can be attributed to the micronotches introduced into the polymer matrix. This applies particularly to the reinforced

Hostaform® POM grades, but also to C 9021 TF, C 9021 G and C 2521 G; with these grades, there is a marked reduction in impact strength but notched impact strength is also lower. This tendency is also discernible with C 9021 K.

For the same reason, Hostaform® POM formulated with black 10/1570 also has slightly lower toughness than the corresponding natural grades.

In the case of EC140XF, EC270TX, the loss of toughness associated with the electrically conductive carbon black content is partially offset by incorporating an elastomer component.

In drop tests, the decline in toughness of the reinforced and filled grades compared with unreinforced grades is less pronounced than in the impact and notched-impact strength tests. This is the reason why moldings produced from these grades have adequate design strength, even under impact stress.

### 3.1.3.3 Hostaform® POM/elastomer blends

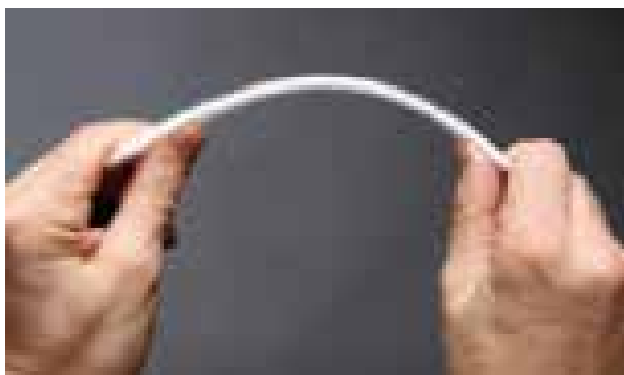
The good toughness of the basic grades can be raised to an even higher level by the addition of suitable elastomers. These grades are therefore blends and are given the name Hostaform® POM S.

Their toughness depends on the type and content of elastomer. The last digit of the code designation indicates the level of toughness, i.e., the higher the last digit, the higher the toughness, while at the same time, strength, hardness and rigidity decrease.

The following figures provide information on the nature of the improved toughness and the level of increase. **Fig. 13** shows the work to damage and **Fig. 15** the deformation – in each case as a function of temperature.

#### Dual Gated Tensile Bar Test

Hostaform® S 9364



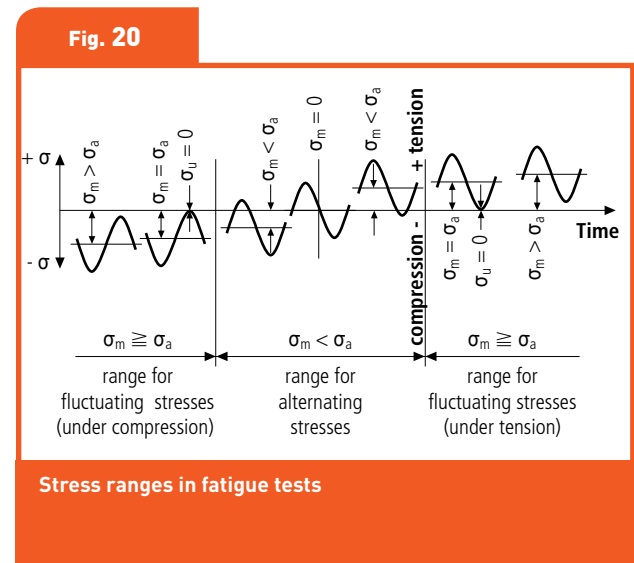
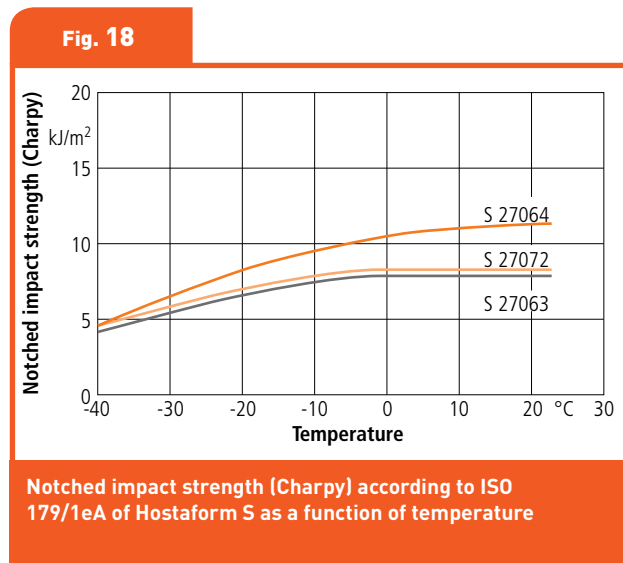
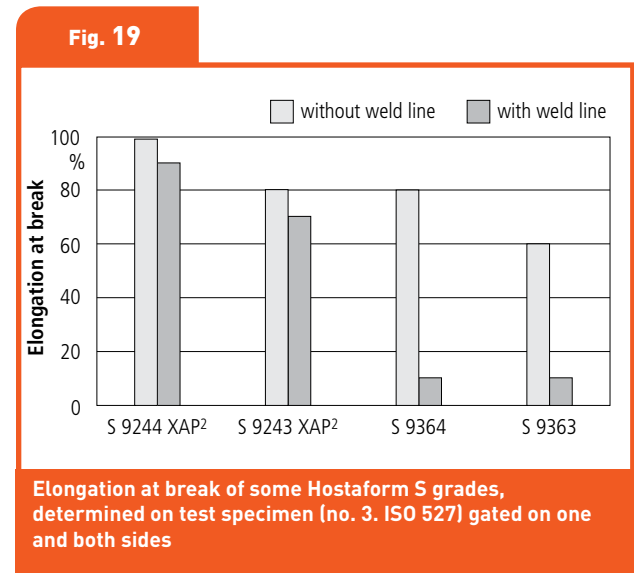
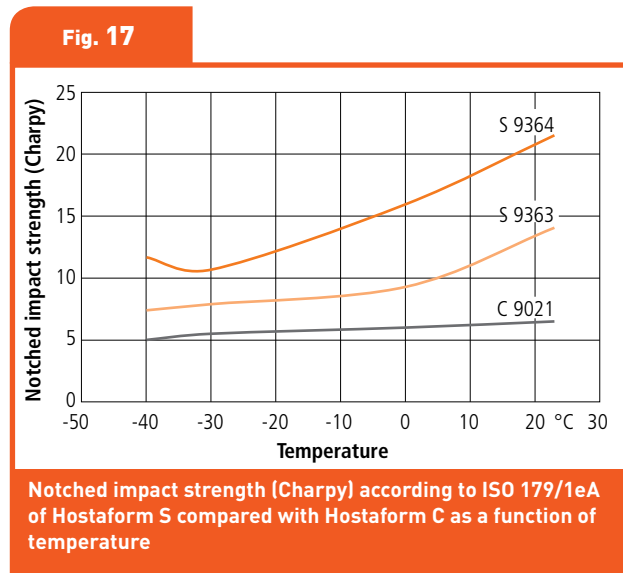
TPU impact modified POM



**Fig. 17** and **Fig. 18** show the effect of temperature on the notched-impact strength of the S grades; **Fig. 17** makes a comparison with Hostaform C 9021.

At room temperature, a differentiation can be seen; at -40 °C, most grades are at the same level while grades S 9243 XAP<sup>2</sup> and S 9244 XAP<sup>2</sup> show significantly better toughness.

Grades S 9243 XAP<sup>2</sup> and S 9244 XAP<sup>2</sup> have flow properties comparable with those of S 9363 and S 9364 but can be processed without macroscopic phase separation (delamination). In addition, they have high weld strength. As can be seen from **Fig. 19**, the elongation at break values of test specimens gated on one and both sides are practically the same.



### 3.1.4 Properties under cyclic stress

Structural components subject to periodic stress must be designed on the basis of fatigue strength, i.e., the cyclic stress amplitude  $\sigma_a$  obtained in the fatigue test – at a given mean stress  $\sigma_m$  – which a test specimen withstands without failure over a given number of stress cycles, e.g.,  $10^7$ , (“Wöhler curve”). The various stress ranges in which tests of this nature are conducted are shown in **Fig. 20**.

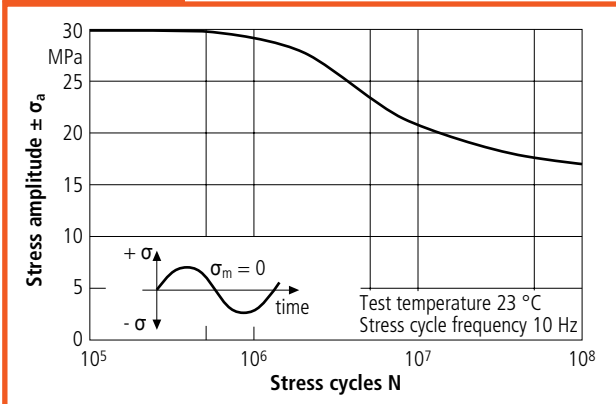
For most plastics, the fatigue strength after  $10^7$  stress cycles is 20 to 30% of the ultimate tensile strength determined in a tensile test. It decreases with increasing temperature and stress cycle frequency, and with the presence of stress concentration peaks in notched components.

In the following figures, Wöhler curves are shown for Hostaform C 9021 (applicable with good approximation to the other basic grades as well) and also for Hostaform C 9021 GV 1/30 (determined in the alternating and fluctuating flexural stress ranges).

The Wöhler curve for tensile/compressive alternating stress is reproduced in **Fig. 21**. According to the diagram, the fatigue strength under tensile/compressive alternating stress for  $10^7$  stress cycles amounts to  $\sigma_w = \pm 20$  MPa.

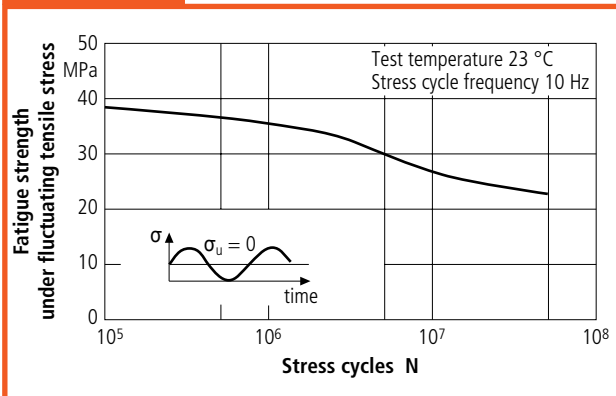
**Fig. 22** shows the behavior of Hostaform® POM in the fluctuating tensile stress range.

**Fig. 21**



Wöhler curve for Hostaform C 9021, determined in the tensile/compressive alternating stress range (test specimen 3 from tensile test ISO 3167; also a good approximation for the other unmodified Hostaform grades)

**Fig. 22**



Wöhler curve for Hostaform C 9021, determined in the fluctuating tensile stress range (test specimen 3 from tensile test ISO 3167; also a good approximation for the other unmodified Hostaform grades)

The Wöhler curves for alternating flexural stress obtained with test specimen 1 (6 mm thick) are shown in **Fig. 23** and those for fluctuating flexural stress in **Fig. 24**.

Similarly, in fatigue strength tests under torsional stress, values under fluctuating and alternating torsional stress conditions are determined. The Wöhler curves obtained on test specimens with a circular cross-section (diameter in the measuring zone 8 mm) at room temperature and a test frequency of 10 Hz are shown in **Fig. 25** and **Fig. 26**.

### 3.1.5 Surface properties

Hostaform® POM has outstandingly good surface properties, such as hardness, abrasion-resistance and low-friction behavior, which are important in many technical applications.

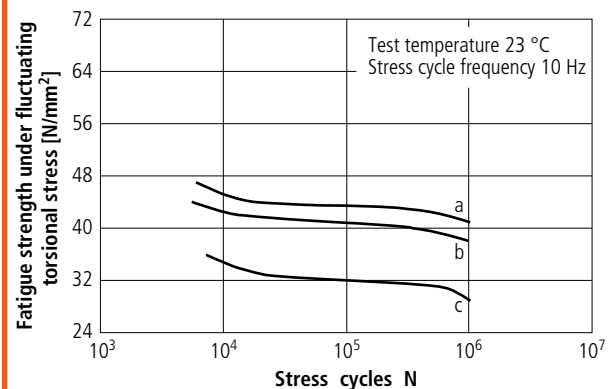
### Hardness

For thermoplastics, it is customary to determine ball indentation hardness in accordance with ISO 2039 part 1. The effect of temperature on the ball indentation hardness of Hostaform® POM C 9021 is shown in **Fig. 27**.

The other basic grades have comparable hardness, except the grades C 2521 and M30AE, based on the low molecular weight POM.

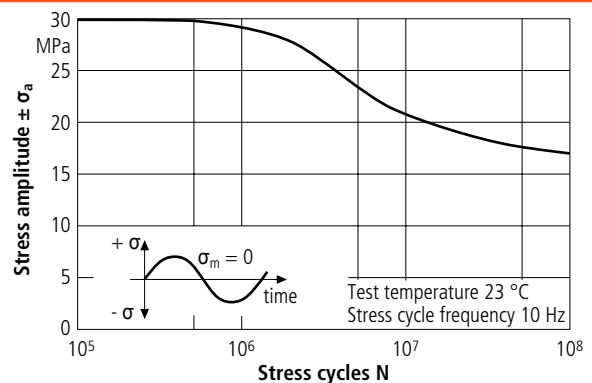
The reinforced grades have a higher ball indentation hardness than Hostaform® POM C 9021 while the high-impact grades possess lower hardness. In each case, the type and quantity of reinforcing material or additive makes a difference to the actual hardness value.

**Fig. 23**



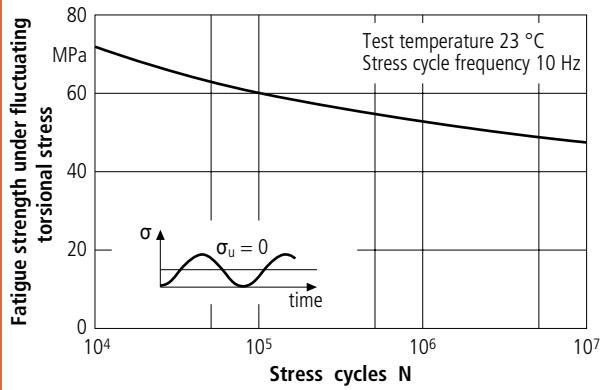
Wöhler curves for Hostaform S9362 (a), S9363 (b) and S9364 (c), determined in the alternating flexural stress range

**Fig. 24**



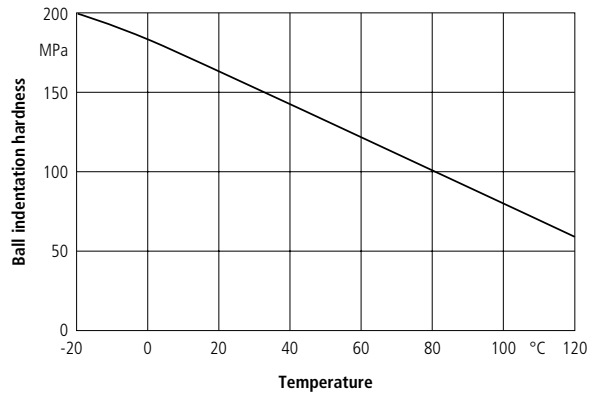
Wöhler curve for Hostaform C 9021 GV 1/30 (a) and Hostaform C 9021 (b), determined in the fluctuating flexural stress range (curve b is also a good approximation for the other unmodified Hostaform grades)

**Fig. 25**



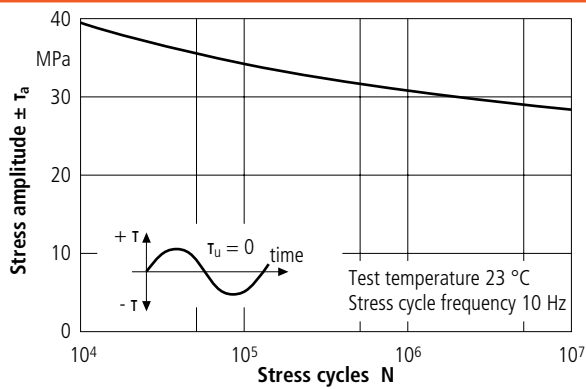
Wöhler curve for Hostaform C 9021, determined in the fluctuating torsional stress range (also a good approximation for the other unmodified Hostaform grades)

**Fig. 27**



Ball indentation hardness of Hostaform C 9021 as a function of temperature (according to ISO 2039 part 1, 30-sec values)

**Fig. 26**



Wöhler curve for Hostaform C 9021, determined in the alternating torsional stress range (also a good approximation for the other unmodified Hostaform grades)



### 3.1.6 Tribology/Slip and wear properties

In engineering, tribological factors have to be taken into account in all applications involving systems of mechanical motion. Through increased use of existing tribological knowledge, it is possible not only to optimize component operation but also to achieve savings in energy, material use and maintenance costs. Hostaform® POM can make an important contribution here since its structural characteristics, linear polymer chains and high crystallinity have proved advantageous for tribological applications.

Because of its good slip properties and high wear-resistance, Hostaform® POM has already established itself in many tribological applications.

#### 3.1.6.1 Tribology, friction and wear

The term tribology refers to systematic studies on the friction and wear of interacting surfaces in relative motion. It also includes lubrication, which is one of the most influential factors. The application of tribological knowledge leads to optimized systems of mechanical motion. It can contribute to increased service life, reduced energy consumption, and improved performance of the complete system.

To find the optimum solution to a problem, all the influencing factors in a tribological system must be known. These include the input variables, structure of the tribological system and output variables.



### Sliding component/Sliding partner

- ▶ Volume properties
  - Material properties
  - Physical (e.g., strength, modulus)
  - Chemical
  - Structural (e.g., crystallinity)
  - Mechanical

---

- ▶ Geometric properties
  - Shape
  - Dimensions

---

- ▶ Surface properties
  - Material properties
  - Physical (e.g., surface tension)
  - Chemical (e.g., reactive constituents)
  - Structural (e.g., hard particle content)
  - Mechanical (e.g., hardness)

---

- ▶ Geometric properties
  - Roughness (e.g., average roughness height)
  - Thickness of the surface layer

### Effect of operating environment

- ▶ State of aggregation – Material properties
  - Physical (e.g., viscosity, moisture)
  - Chemical (e.g., oxygen content, polarity)

### External influences

- ▶ Type of motion (sliding, rolling, jerky)
  - Motion (constant, oscillating)
  - Load (constant, percussive, intermittent)
  - Sliding speed
  - Temperature (ambient temperature, frictional heat, external temperature, control)

### Interfacial medium

- ▶ State of aggregation
  - if solid: geometric properties

---

- ▶ Material properties
  - Physical (e.g., strength)
  - Chemical (e.g., resistance to oxidation)

---

- ▶ Mechanical
  - Structural (e.g., hardness)

Over a number of years Celanese has systematically built up a tribological competence center, in which specialists in research and material/application development advise customers, develop new grades to customer requirements and continually generate new knowledge in the area of tribology. Through the application of this knowledge, it is possible not only to improve component functions but also to achieve savings in energy, material consumption and maintenance costs.

Materials for tribologically stressed components are frequently characterized by their friction coefficient and wear resistance. These are not characteristics of the material per se but of the particular tribological system. For the purposes of research and development, Celanese operates various test facilities and systematically generates tribological data.

The measurable properties of the tribological system are friction and wear. These values are influenced by material properties, the interactions occurring between the surfaces in motion and the effects of the input variables. It is therefore necessary to determine as accurately as possible the characteristic values, structure of the tribological system, input variables and output variables.



### Effect of surface roughness on friction

For example, when the paired materials are steel and POM, adhesive sliding force predominates if the surfaces of the sliding partners, particularly that of steel, are very smooth and the surface pressure loading is very low. With increasing surface roughness and surface pressure loading, the adhesive sliding mechanism diminishes and the deformation force component increases **Fig. 29a**.

### Dynamic loadbearing capacity of the tribological system

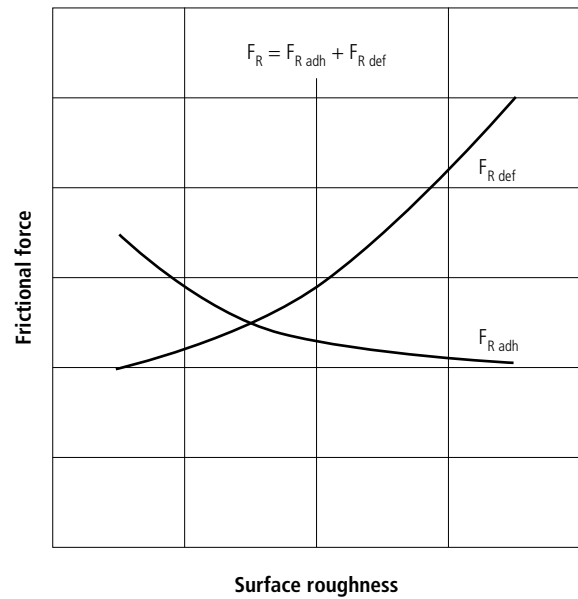
Low friction forces make it possible to minimize frictional heat, which is a major obstacle to the successful use of paired plastics in sliding applications. If a system-specific critical load is exceeded, wear increases sharply. As a design criterion, e.g., for the dynamic loadbearing capacity of slide bearings, a maximum permissible  $p v$  value is sometimes specified. This is the product of the surface pressure loading  $p$  and sliding speed  $v$ .

The product  $p v$  is not a constant design criterion. With increasing sliding speed the surface pressure loading must be disproportionately reduced in order not to exceed the critical load.

In summary, it can be said that the adhesion component of frictional force depends on the formation of adhesive bonds at the interfaces. In an unfavorable case, these can lead to material transfer and welding. When the adhesive contact bridges are separated deformation forces inevitably arise. However, the mechanism of abrasion is mainly described by the penetration of the harder sliding partner into the softer partner in tangential motion. When steel is the base component, less wear is expected on the counter-component the greater its energy absorption is.

With plastic/plastic pairings, it is important to establish which one is the sliding component and which one is the stationary component, which component is in permanent contact and which can recover periodically because its surface is released from contact. In such pairings, it is particularly important to pay attention to the interaction of morphology, mechanics and energetics at the sliding contact site.

Fig. 29a



Adhesion and deformation components of frictional force as functions of surface roughness



### 3.1.6.1.2 Influencing factors

The energetic and mechanical effects on friction and wear are often not the only disruptive influences. It is also possible for chemical effects such as reactive changes, oxidation and degradation to take place during tribological stressing of the paired sliding partners. Some slip-modified Hostaform® POM grades are unsuitable for contact with fuels because the lubricant in the material is swollen or dissolved. At the same time, the material itself can also swell, leading to warpage and failure of the components in sliding contact. If the sliding partners come into contact with external media (e.g., lubricants), this can result in an increased tendency to stress cracking.

If the tribological system is exposed to high ambient temperatures, loads or speeds, the sliding surface temperature also increases. If the sliding surface temperature exceeds the melting point of one of the sliding partners, this can result in catastrophic failure of the tribological system. This is manifested in a sudden increase in wear. Because of the significantly better thermal conductivity of metal, a metal/ plastic combination can withstand higher loads and speeds than a plastic/plastic combination despite poorer sliding behavior, since the frictional heat is removed faster from the system.

From the design perspective, it should be borne in mind that in thin-walled components, lubricant particles can act as notch points. The position and size of lubricant particles can also have an influence on weld line strength.

### 3.1.6.1.3 Noise emissions

Noise, like friction, is a form of energy. Noise is generated in a solid body if mechanical energy is introduced into it from outside. It is propagated in wave form. The vibrations of the solid body are transmitted to the surrounding air and only then can they be heard by the human ear. Noise emission can be suppressed by reducing the amount of energy introduced, e.g., by optimizing the geometry and surface quality of the tooth flanks of a gearwheel (external damping) or by preventing structure-borne sound transmission (internal damping). In the latter case, sound damping essentially takes place by conversion of the sound energy into internal losses through the use of elastic materials.

Squeaking is a particularly unpleasant effect caused by the stick-slip phenomenon. This is when two materials in relative motion alternate between a state of static and dynamic friction. Stick-slip occurs particularly in pairings of unmodified POM with itself. The problem can be overcome by external lubrication or by selecting a higher-quality, slip-modified Hostaform® POM grade as one of the paired components.

For objective testing of squeaking by components in sliding contact, ZINS Ziegler-Instruments GmbH in Mönchengladbach, Germany, supplies suitable test rigs.

### 3.1.6.2 Celanese's Tribology

#### Equipment Overview

MCR301 Test device to check breakaway torque, high-speed movements and pv limits

In the past, it was only possible to measure static friction after some sliding cycles, which does not simulate the first sliding contact. New equipment from Anton Paar Germany GmbH is able to start from zero point of movement, completely different from other tests. The idea of Anton Paar was to design an accessory which turns a rheometer into a high-resolution tribometer based on a ball-on-pyramid principle, mainly to check liquid oil-lubricated materials[2]. Celanese optimized the method to test dry polymers with incorporated lubrication.

All test specimens are injection molded plates and spheres, like in real applications. The geometry ball-on-plate leads to low contact area, high pressure loads and defined contact areas, which increases the level and sensitivity of the breakaway forces. Carving effects, as in plate-on-plate geometries, can be avoided. Further possibilities are variations of temperatures and compression time.

Fig. 28

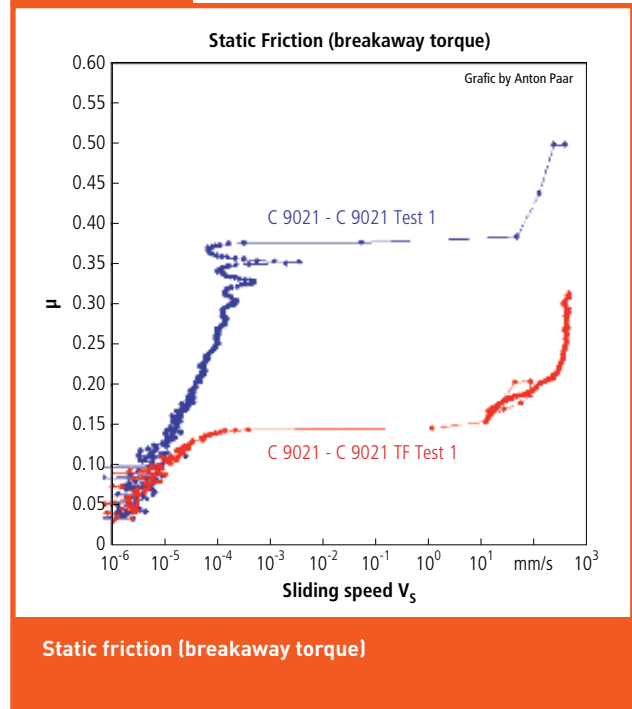
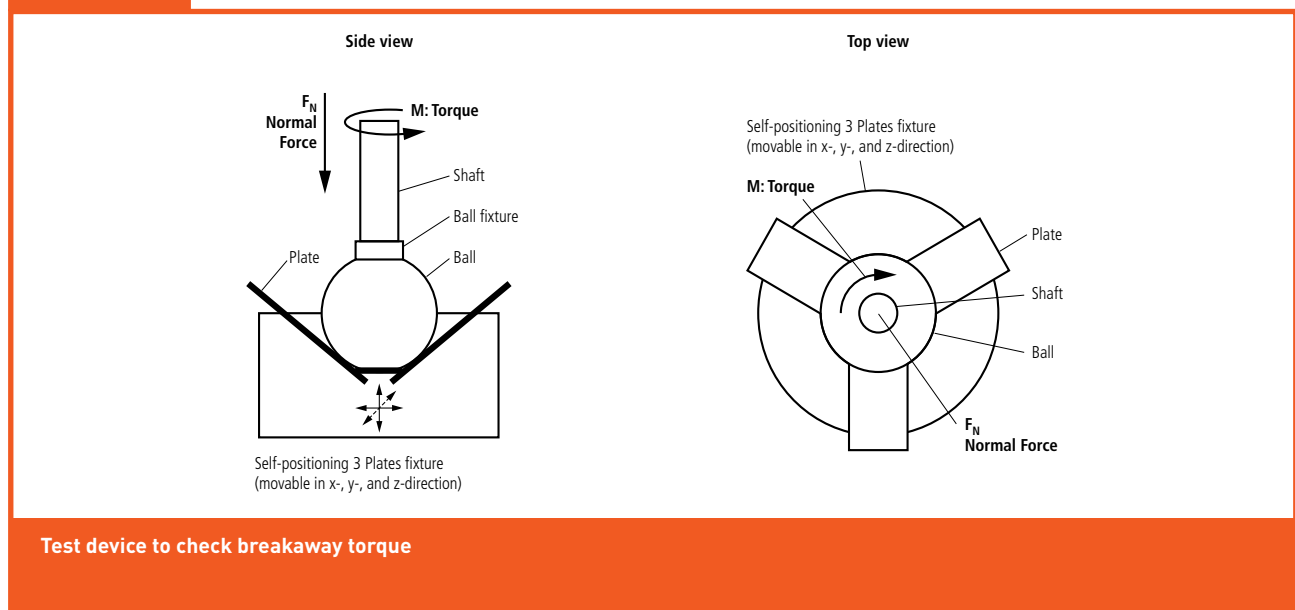


Fig. 29b



Test device to check breakaway torque

Tribology device: Ball-on-3-plates principle Peltier bottom plate and Peltier hood



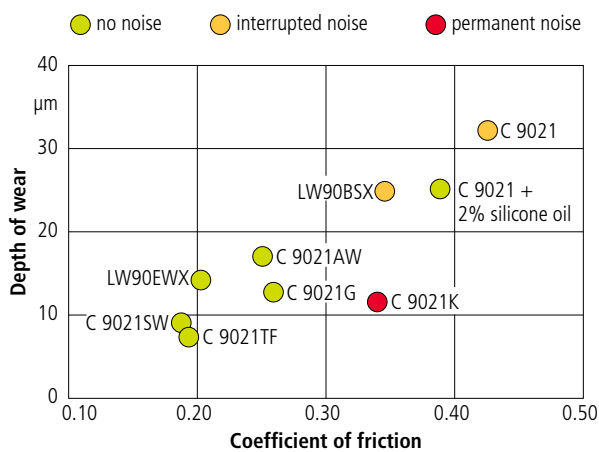
The test equipment can also be used to determine the friction and wear for high-speed movements. An example is given in Fig. 30. Here, a steel ball is rotating against different POM materials.

By variation of the rotation speed the pV limit of a material combination can be detected.

For testing of slow speed/high pressure, we use a stick-slip test device supplied by Zins Ziegler-Instruments GmbH, Mönchengladbach, Germany.

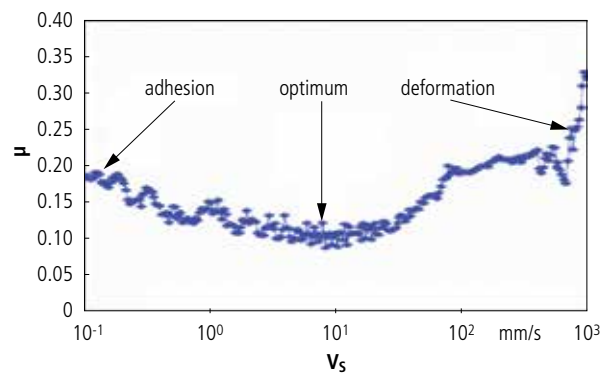
The function principle is shown in the graph Fig. 31

Fig. 30



Ball of steel polished vs. POM grades ( $v = 100 \text{ mm/s}$  /  $F = 5 \text{ N}$  / one-direction movement/friction, wear + noise after 1 h)

Fig. 31

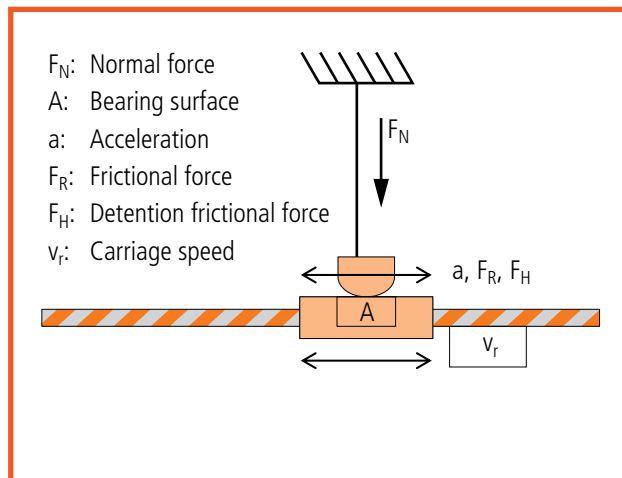


Stick Slip Test device – Influence of adhesion & deformation on sliding speed (POM-POM contact, ball-on-3 plates,  $F = 3 \text{ N}$  /  $t = 5 \text{ min}$ )

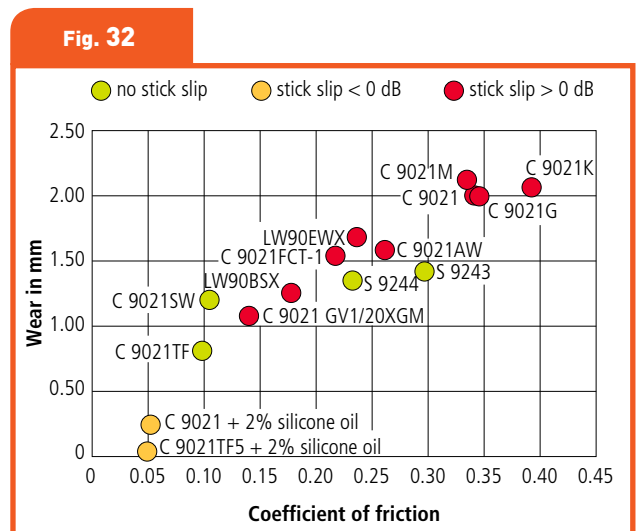
The normal force can be regulated between 2 N and 30 N by use of a pneumatic system. According to the equation of Hertz (ball-on-plate calculation), high surface pressures close to the compressive strength at yield can be applied.

The velocity of the moving table can be adjusted up to 10 mm/s.

The friction force is measured by the elongation of a metal spring (strain gage). The acceleration of the spring is determined by a sensor. By use of an algorithm, a risk priority number (RPN) is calculated, which correlates the stick-slip behavior with the tendency of noise generation. The following graph gives an overview for various Hostaform grades when sliding against a ball made from Hostaform C 9021 (FN 12,5 N). The risk that a pairing generates noise is coded in the color. **Figure 32**



The carriage with the sample of a material A is moved past at the feather/spring with the sample of a material B. Carriage speed and normal force are adjustable.



Ball Hostaform C 9021 vs. Hostaform grades (T = 23 °C / friction, wear + stick slip after 45 min)

$$p_{H, \max} = \frac{1}{\pi} \cdot \sqrt{\frac{1,5 \cdot F \cdot E_{\text{ges}}^2}{r^2 \cdot (1 - \nu^2)^2}}$$

$F$  = Normal Force                       $r$  = Radius of the ball  
 $E_{\text{ges}}$  = overall-E-Modul with             $\nu$  = Poisson's ratio  
 =  $2 \cdot E_1 E_2 / (E_1 + E_2)$

Calculation of Hertz Pressure  $p_{H, \max}$



### 3.1.6.3 Materials for pairing with Hostaform® POM in sliding applications

Among metals, steel is the most suitable sliding partner for POM. The harder the steel base component is, the lower the wear of the Hostaform® POM counter-component. Steel with a Rockwell hardness of at least 54 HRC is recommended. The roughness height Rz should be about 2 to 0.5 µm. Stainless steel behaves less favorably than standard steel, especially in combination with PTFE-modified Hostaform® POM.

Until recently, the advice has been that nonferrous metals were not so suitable for sliding contact with Hostaform® POM and that if the use of aluminum was unavoidable, then only anodized grades should be chosen. However, with the further development of new, slip-modified Hostaform® POM grades, serviceable combinations can now also be achieved with these metals.

For combinations of Hostaform® POM in sliding contact with other plastics, divergent, i.e., repelling, polymers are preferred because these have no tendency to weld. Unmodified POM should only be paired with itself when there is a very low tribological load. Because of their permanent dipoles, polar polymer materials such as POM have a high polar surface energy component, which is associated with high adhesive forces and therefore with high friction losses. To reduce the high adhesive forces occurring with POM, nonpolar

materials such as PTFE or PE can be incorporated into it. For satisfactory sliding action, small quantities of lubricant are generally sufficient. To neutralize polarity, however, significantly larger additions are required, which can then influence other properties such as mechanical ones. In selecting a material pairing, it is therefore important to consider whether the sliding partner chosen for Hostaform® POM can be such that a Hostaform® POM grade with low lubricant addition suffices. Suitable materials would be, for example, polyester or polyamide. In pairing Hostaform® POM with itself, at least one of the sliding partners should be made from a higher-quality, slip-modified Hostaform® POM.

### 3.1.6.4 Recommendations for pairing with Hostaform® POM in sliding applications

In the material brochures or data sheets, you can search in vain for tribological properties such as coefficient of friction or wear rate. The reason for this is that these values are not purely material values, but depend on the particular systems in which they are used and the conditions under which these systems operate. The applicability of test results obtained on special test rigs to other systems is therefore limited. The following tribological information therefore relates to slide-bearing tests under the following conditions.

Sliding partners					
Metal		Plastics		POM	
Steel	Brass Aluminum	Semi-crystalline (PBT, PA)	Amorphous (PC, PMMA)	C 9021	Against itself

SQUEAKING	FRICTION COEFFICIENT	WEAR
BSX, SW, AW, SOEK, TF	AW, SW, TF, BSX, EWX, SOEK	AW, BSX, SW, EWX, TF, K, SOEK, RM
BSX, SW, TF	EWX, SW, AW, BSX, TF	BSX, SW, AW, TF, EWX
BSX, SW, AW	EWX, SW, AW, BSX	BSX, EWX, AW, SW, FCT1
BSX, SW, TF	SW, BSX, EWX, TF	BSX, EWX, SW, TF
BSX, SW, SOEK, AW, TF	AW, BSX, SW, SOEK, TF	BSX, SW, AW, TF, SOEK
BSX, SW, AW, TF	BSX, SW, TF, AW	BSX, SW, TF, AW

The tribological navigator lists the Hostaform® POM slip/wear modified grades that give the best results in terms of friction coefficient, wear or squeak resistance in sliding motion against the specified partner material in model trials.

The navigator is intended to help development engineers in industry make a preliminary selection of the most suitable grades from the special range of Hostaform® POM slip/wear modified materials. Because of the limited applicability of model trial results to real systems, the tribological navigator should be used solely as an initial guide. The suitability of a chosen Hostaform® POM tribological grade for a specific application must always be tested under real operating conditions.

Due to space constraints, the complete product names are not given. Only the abbreviated forms are used to designate the individual products.

Mechanical properties are not taken into account in the tribological navigator. The most important mechanical properties of the Hostaform® POM slip/wear-modified grades are presented in the table.

### **Tribological additives**

Generally speaking, the use of tribological additives reduces the strength of Hostaform® POM. However, Celanese has addressed this problem by developing the tribologically modified specialty grades Hostaform® POM C 9021 GV 1/30 GT and Hostaform® POM C 9021 GV 1/10 GT (previously supplied as development grade Hostaform® POM X 341/37). These not only exhibit the increased strength typical of glass-fiber reinforced Hostaform® POM but also offer improved slip/wear properties.

Silicone oil modified grades also have good weld line strength and notched impact strength and virtually match the mechanical property profile of unmodified Hostaform® POM.

To produce components modified with silicone oil, Celanese recommends adding silicone oil concentrate Hostaform® POM C 9021 SOEK to Hostaform® POM standard or specialty grades.

Among the classic Hostaform® POM tribological grades are those modified with PTFE. Celanese supplies PTFE-modified grades with different filler loadings (TF: high filler loading, TF5: moderate filler loading) in combination with different flow characteristics (C 9021: standard flowability, C 27021: easyflowing). These grades are preferred sliding partners for smooth steel and PMMA surfaces and generally for applications requiring a low coefficient of friction.

The chalk-filled grades Hostaform® POM C 9021 K and Hostaform® POM C 13031 K are particularly suitable for sliding elements that are continuously lubricated or operate with permanent lubrication. Chalk filled grades are less suitable for sliding against rough surfaces.

For conditions such as this, where there is high abrasive stress, the Celanese grades C 2521 G and C 9021 G are recommended.

### **Noise emission**

If the aim is to minimize noise emission from the sliding element to reduce squeaking as much as possible, Hostaform® POM C 9021 SW and Hostaform® POM LW90BSX are the materials of choice. Hostaform C 9021 AW also gives good results here in many cases.

The molybdenum disulfide-filled grades Hostaform® POM C 2521 M and C 9021 M are suitable for applications in which high surface-pressure loadings and very low sliding speeds occur at the same time. These grades reduce the stick-slip effect, which can generate considerable noise..

### **Thermoplastics as sliding partners**

Hostaform® POM SLIDEX 0313 has the widest tribological application of all the slip/wear-modified Hostaform® POM grades. It may be considered a tribological all-rounder. With Hostaform® POM SLIDEX 0313, no external lubrication is generally necessary.

Hostaform® POM SLIDEX 0313 is an ideal sliding partner for all thermoplastics, steel and nonferrous metals. When thermoplastics slide against each other, it is often a disadvantage to use the same grade for both sliding partners, since the similar polarity of the surfaces gives rise to increased wear stress. The Hostaform® POM grade SLIDEX 0313 was developed as an allrounder material sliding against POM, other plastics and metals. It is modified with special additives that change the polarity of the component surface. Hostaform® POM SLIDEX 1313 is particularly suitable for pairing with other thermo-plastics as the sliding partner.

### Grades specially for use in the food sector

Hostaform® POM grades C 9021 FCT1, C 13021 RM and LW90EWX are tribologically modified with special additives. Their mechanical properties are decreased less than those of other more highly modified grades and better weld line strength is achieved. Hostaform® POM SLIDEX 0303 and SLIDEX 0313 also comply with FDA recommendations for use in the food sector.

### Overview of mechanical properties and tribological behavior

Grade	Lubricant	Tensile modulus [MPa]	Yield stress [MPa]	Elongation at break [%]	Notched impact strength [kJ/mm <sup>2</sup> ]	Weld line strength	Tendency to squeaking	Wear against steel	Wear against POM	FDA conformity
C 9021	none	2850	64	30	6.5	↑↑↑↑↑	↑↑↑↑↑	↑↑↑	↑↑↑↑↑	+
LW90BSX	special + silicone oil	2550	52	35	5.5	↑	↑	↑	↑	-
C 9021 SW	special + chalk	2850	53	16	4.0	↑	↑	↑	↑	-
C 9021 AW	special lubricant	2600	58	20	6.0	↑	↑↑	↑	↑	-
C 9021 GV 1/30 GT	glass fibers + PE-UHMW	8500	95	-	4.8		↑↑	↑↑	↑↑↑↑↑	-
C 9021 GV 1/10 GT (X 341/37)	glass fibers + PE-UHMW	4400	75	-	6.0		↑↑	↑↑	↑↑↑↑↑	-
C 9021 SOEK	silicone oil concentrate	2600	51	30	5.3	↑↑↑↑	↑↑	↑	↑↑↑	+
C 9021 TF	PTFE	2500	50	16	4.0	↑	↑↑	↑	↑↑	+
C 9021 TF5	PTFE	2600	58	28	6.0	↑	↑↑↑	↑↑	↑↑↑	+
C 27021 TF	PTFE	2300	45	12	4.0	↑	↑↑	↑	↑↑	+
C 27021 TF5	PTFE	2600	58	25	6.0	↑	↑↑↑	↑↑	↑↑↑	+
C 2521 G	PE-UHMW	2100	44	15	5.0	↑	↑↑	↑↑	↑↑↑	+
C 9021 G	PE-UHMW	2300	45	10	3.5	↑	↑↑	↑↑	↑↑↑	+
C 9021 K	chalk	3000	60	22	5.0	↑↑↑↑	↑↑↑	↑	↑↑↑	+
C 13031 K	chalk	3100	64	15	5.0	↑↑↑↑	↑↑↑	↑	↑↑↑	+
C 9021 M	MoS <sub>2</sub>	2800	65	20	6.0	↑↑↑↑	↑↑	↑↑↑	↑↑↑↑	-
C 13021 RM	wax	2800	64	25	6.5	↑↑↑↑	↑↑↑	↑↑	↑↑↑↑	+
C 9021 FCT1	wax	2700	62	30	7.0	↑↑↑↑	↑↑↑	↑↑	↑↑↑↑	+
LW90EWX	wax	2700	61	28	7.0	↑↑↑↑	↑↑↑	↑	↑↑↑↑	+
SLIDEX 0313	special lubricant	2700	60	40	6.0	↑↑↑↑	↑↑↑	↑↑	↑↑↑↑	+
SLIDEX 0304	special lubricant	2600	56	45	5.5		↑	↑	↑	+

Data on tribological behavior: ↑ low    ↑↑↑↑↑ high    |    The values quoted for C 9021 SOEK relate to the 1:10 blend with Hostaform C 9021

### 3.2 Thermal properties

The most important thermal properties of a plastic include:

- ▶ melting point, transition temperatures or phase change regions, specific heat, enthalpy, thermal conductivity, coefficient of expansion
- ▶ thermal stability (stability of the melt at processing temperature).

#### Specific heat

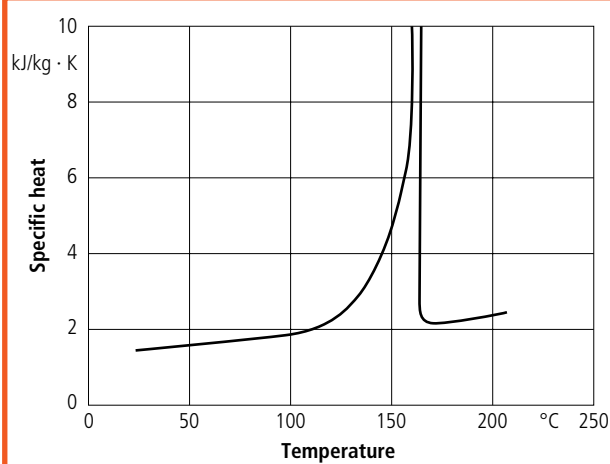
**Fig. 38** shows the specific heat of Hostaform® POM C 9021 as a function of temperature. The increase in enthalpy, calculated from the specific heat and based on an enthalpy value of zero at 20 °C, is shown in **Fig. 39**.

It is essential in designing processing machines and in design calculations for molded parts to know how much heat must be supplied or removed in processing Hostaform® POM. In determining the approximate amount of heat to be removed, for example, in cooling the Hostaform® POM melt from 220 °C to 90 °C, the following procedure is adopted

**Fig. 39.**

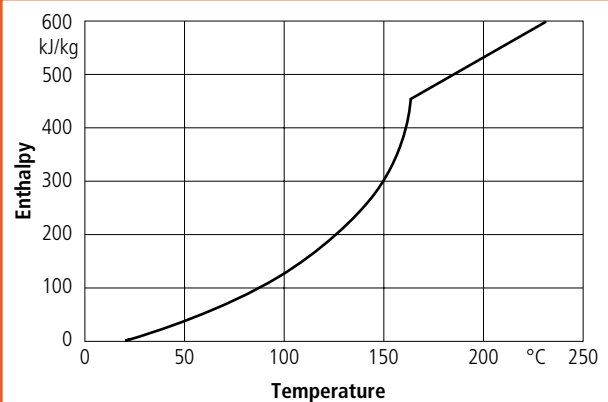
enthalpy at 220 °C	586 kJ/kg
– enthalpy at 90 °C	105 kJ/kg
<b>= heat to be removed</b>	<b>481 kJ/kg</b>

**Fig. 38**



Specific heat of Hostaform C 9021 as a function of temperature

**Fig. 39**



Enthalpy curve for Hostaform C 9021 (based on 20 °C)



### Specific volume

The specific volume (= reciprocal of density) of the Hostaform® POM basic grades can be read off the p-v-T (pressure-specific volume-temperature) graph for the temperature range 20 - 250 °C **Fig. 40**.

### Thermal conductivity

The thermal conductivity of the Hostaform® POM basic grades at 20 °C is  $\lambda = 0.31 \text{ W/m} \cdot \text{K}$ ; for Hostaform® POM 9021 GV 1/30, the conductivity value is  $0.41 \text{ W/m} \cdot \text{K}$  and for the high-impact grades ranges between  $0.27$  and  $0.34 \text{ W/m} \cdot \text{K}$ .

### Coefficient of linear expansion

The linear expansion coefficient  $\alpha$  of the Hostaform® POM basic and reinforced grades is shown in **Fig. 41** as a function of temperature. As with most materials, it increases with rising temperature. As can also

be seen from **Fig. 41**, the glass-fiber reinforcement reduces both the value and the rate of increase of  $\alpha$ . Furthermore, with Hostaform® POM 9021 GV 1/30,  $\alpha$  is dependent on flow direction because of orientation of the glass fibers during processing.

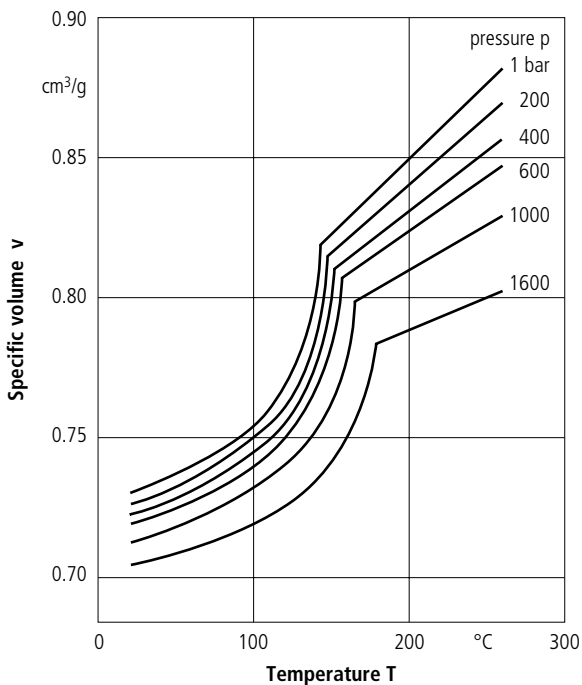
The Hostaform® POM S grades have about a 20 to 30% higher expansion coefficient than the basic grades.

Using the mean value for the coefficient of linear expansion  $\bar{\alpha}_m$ , the length  $l$  of a molding at temperature  $\vartheta$  may be calculated according to the equation:

$$l_{\vartheta} = l_0 [1 + \bar{\alpha}_m (\vartheta - \vartheta_0)] \quad (4)$$

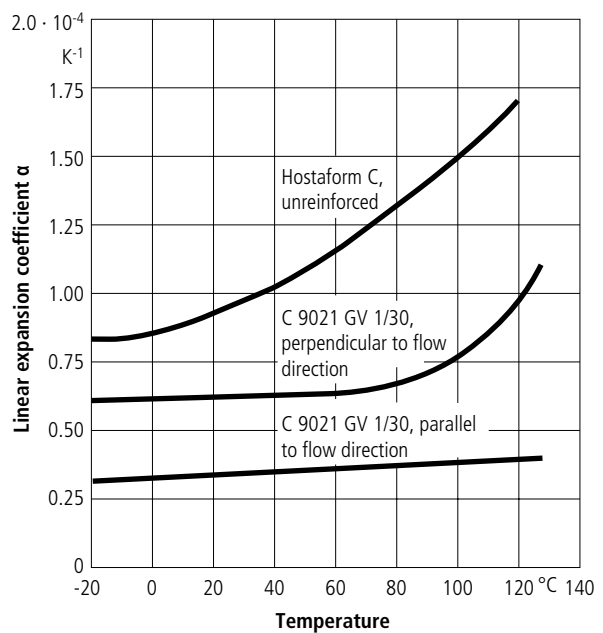
where  $l_0$  is the length of the molded article at the reference temperature  $\vartheta_0$ . The mean value  $\bar{\alpha}_m$  at various temperatures can be read off **Fig. 41**.

**Fig. 40**



Specific volume  $v$  of unreinforced Hostaform C as a function of temperature  $T$  and pressure  $p$  (p-v-T-graph), measured at a cooling rate of  $12 \text{ K/s}$

**Fig. 41**

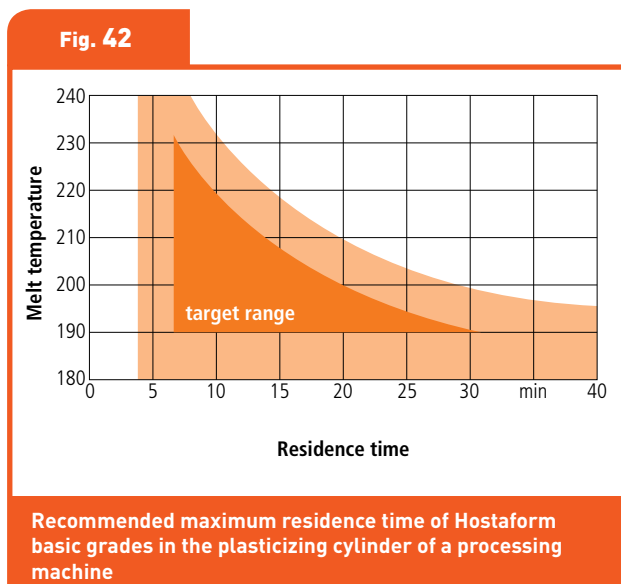


Linear expansion coefficient  $\alpha$  of unreinforced Hostaform C and Hostaform C 9021 GV 1/30

### Thermal stability

Thermal stability is meant here in its narrow sense, i.e., the thermal stability of the melt at processing temperature. The thermal stability of Hostaform® POM PO derives from comonomer units with stable C-C bonds, which are statistically distributed in the molecular chains of the base polymer. When the polymer is subject to thermo-oxidative attack, chain scission does indeed start to occur, accompanied by formation of low-molecular-weight polymers and thermally unstable end groups. However, degradation can proceed only as far as the next comonomer unit, is therefore minimal, and the remaining fragments are thermally stable. The rate of thermo-oxidative attack increases with the rise in temperature, while the extent of the attack is time-dependent.

For this reason, it is advisable to remain within the target-processing range shown in Fig. 42, i.e., the maximum melt-temperature-related residence time of the Hostaform® POM basic grades in the plasticizing cylinder of a processing machine should not be exceeded; the specified range should also be observed when processing the high-impact and glass-sphere reinforced grades.



The minimum residence time of the material regarding the plasticizing unit is also an important property in the process. A too-low residence time leads to a higher material shear and a higher formaldehyde emission, insufficient high melt temperature and a tendency to a higher melt viscosity, followed by a higher pressure drop of the injection pressure for an existing inhomogeneity of the melt that results, finally, in unmelted granules in the molded part. For other semi-crystalline polymers, a minimum residence time of 3 minutes of the cylinder is recommended.

Thermal degradation during processing, e.g., injection molding, which might impair molded-part properties, can be readily determined by measuring the melt-mass flow rates of MVR 190/2.16 and MVR 190/15, and then dividing MVR 190/15 by MVR 190/2.16.

If this value, determined on specimens taken from the molded part, has significantly increased over the value of the starting material, then the molding material has been thermally degraded during processing, and correction of processing conditions, e.g., melt temperature and/or residence time  $t_v$  in the plasticizing cylinder, is required. The following applies:

$$t_v = \frac{\text{weight of melt in the cylinder} \cdot \text{cycle time}}{\text{weight per shot including sprue}}$$

### 3.3 Electrical properties

Hostaform® POM has good electrical insulating and dielectric properties, except for the electrically conductive grades. These, in combination with its good mechanical properties, have made Hostaform® POM a valued material for numerous applications in the electrical sector.

#### Volume resistivity

The volume resistivity of Hostaform® POM is  $\rho_D = 10^{12} \Omega \cdot \text{m}$  for all grades, except for the high-impact and electrically conductive materials; it is therefore largely unaffected by the presence of additives.

Hostaform® POM EC140XF and EC270TX have a considerably lower volume resistivity. This is due to the formation of a current bridge by the electrically conductive carbon black. Destruction of the carbon black morphology and/or strong orientation of the carbon black particles can impair the current bridge and allow volume resistivity to increase. Selection of adequate wall thickness will counteract this; in addition, low injection rates and high mold-wall temperatures should be preferred in processing Hostaform® POM EC140XF and EC270TX.

### Surface resistivity

Surface resistivity gives an indication of the insulation-resistance across the surface of a material. The dependence of this value on humidity and surface contamination must be taken into account. In the case of Hostaform® POM, it is appreciably lower than that exhibited by hydrophilic polymers such as certain specific polyamides.

The surface resistivity of most Hostaform® POM grades is in excess of  $10^{14} \Omega$ . Antistatic modification reduces this to  $10^{13} \Omega$ , while in the case of EC140XF and EC270TX, the value is lowered even further to  $10^3 \Omega$ . The surface resistivity of EC140XF and EC270TX – and also its volume resistivity – can be influenced by processing parameters and molded-

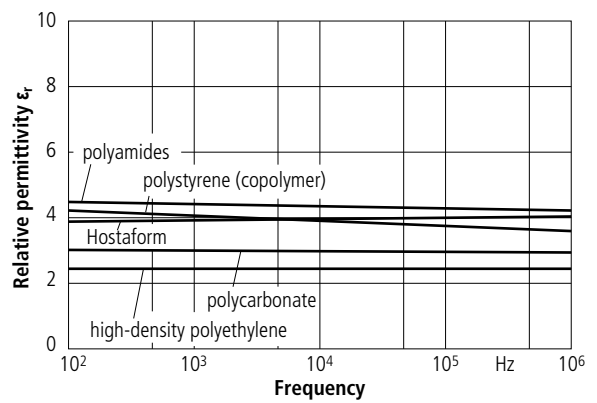
part design. Therefore the electrical properties have to be controlled at the molded part.

### Relative permittivity, dissipation factor

The relative permittivity  $\epsilon_r$  of the unreinforced Hostaform® POM grades is about 4, that of the reinforced grades between about 4 and 5 and that of the high-impact grades between about 3.6 and 5.

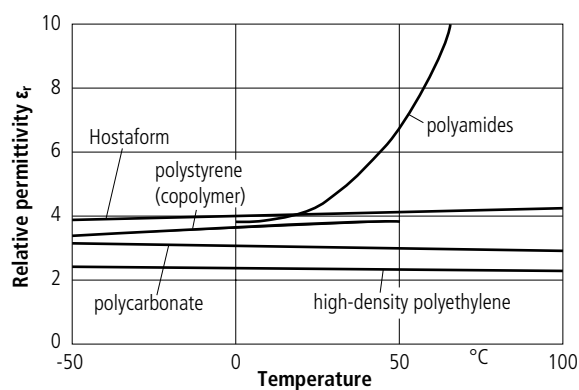
The effect of temperature on relative permittivity is shown in Fig. 43 and the effect of frequency in Fig. 44.

Fig. 44



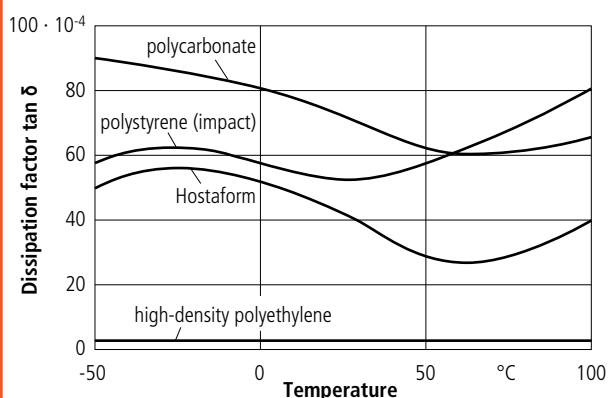
Effect of frequency on the relative permittivity of various plastics (measured at 25 °C)

Fig. 43



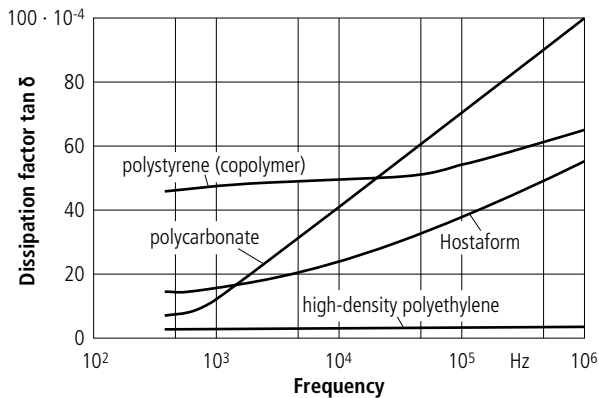
Effect of temperature on the relative permittivity of various plastics (measured at 10<sup>5</sup> Hz)

Fig. 45



Effect of temperature on the dissipation factor  $\tan \delta$  of various thermoplastics (measured at 10<sup>5</sup> Hz)

**Fig. 46**



**Effect of frequency on the dissipation factor  $\tan \delta$  of various thermoplastics (measured at 25 °C)**

The dissipation factor  $\tan \delta$  is a measure of the energy loss in the dielectric by conversion into heat.

Hostaform® POM has a low dissipation factor. Depending on the grade, it is  $10^{-3}$  to  $10^{-2}$  in the frequency range 100 Hz to 1 MHz.

The effect of temperature on the dissipation factor  $\tan \delta$  is shown in Fig. 45 for a frequency of  $10^5$  Hz. Fig. 46 shows the effect of frequency on the dissipation factor  $\tan \delta$  at 25 °C.

The excellent dielectric properties of Hostaform® POM preclude the use of high-frequency heating and welding for this material.

### Dielectric strength

Dielectric strength describes behavior under short-term, high-voltage stress. It is not a measure of permissible continuous stress. In dielectric strength tests, the voltage ( $f = 50$  Hz) is steadily increased at a rate of 1 kV/s until insulation breakdown occurs.

In tests according to IEC 60 243 part 1, the Hostaform® POM basic grades showed dielectric strength values of 28 to 35 kV/mm.

### Static charge accumulation

Hostaform® POM in general does not tend to accumulate static charge. For applications in which dust attraction must be absolutely avoided, however, the use of the antistatic-modified grade Hostaform® POM C 27021 AS has proved successful.

The antistatic modification reduces surface resistivity and at the same time considerably increases the discharge rate, as the following table shows:

Property	Unit	Test method	Hostaform C	
			27021	C 27021 AS
Surface resistivity	$\Omega$	IEC 60 093	$10^{14}$	$10^{13}$
discharge rate* (half-value time)	s	–	about 60	10 to 25

\*Decline in the field strength of a capacitor with the test specimen as a dielectric to 50% of its initial value after charging with 1000 volts.

The antistatic modification has little or no effect on all other properties of Hostaform® POM.

### 3.4 Optical properties

Hostaform® POM moldings range from more or less translucent to opaque-white, depending on wall thickness. When a parallel beam of light falls vertically on a compression-molded sheet with parallel faces, the proportion of diffuse light transmission is as follows:

thickness	1 mm	about 50%
	2 mm	about 35%
	4 mm	about 25%

The refractive index  $n$  for light in the visible wavelength range is 1.48.

Gloss is dependent mainly on the surface quality of the mold.

# 4

## Effect of the service environment on the properties of Hostaform

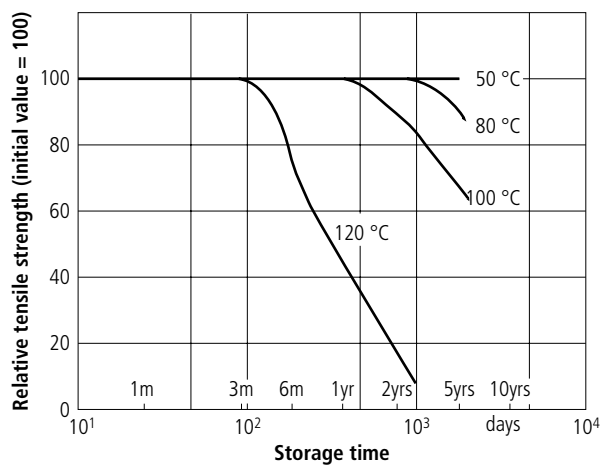
In this section, the properties of Hostaform® POM in the presence of certain media and their dependence, in some cases, on temperature and time of exposure are described. Particular consideration is given to:

- ▶ air at elevated temperature
- ▶ water
- ▶ motor fuel
- ▶ chemicals
- ▶ weathering
- ▶ high-energy radiation
- ▶ flammability

### 4.1 Properties in air at elevated temperatures

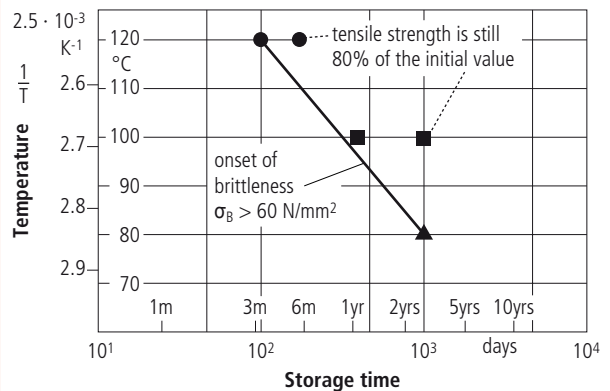
All Hostaform® POM grades are stabilized against thermo-oxidative degradation, so that they can be safely processed if the recommendations for the individual grades in section 5 are followed. In addition, finished parts made from Hostaform® POM are able to withstand heat stresses in service, although the level of heat resistance will depend slightly on the particular grade. The progressive deterioration in properties through heat aging is influenced by a large number of service environment factors in various ways. Terms such as heat resistance, continuous service temperature, etc. therefore do not describe material constants. They should only be considered in the context of particular application requirements. For further material recommendations, please contact your sales representative.

Fig. 47



Relative tensile strength of Hostaform C 9021 as a function of storage time in air at elevated temperature

Fig. 48



Change in the tensile strength of Hostaform C 9021 as a function of storage time and temperature on an Arrhenius diagram

Most Hostaform® POM grades are approved by Underwriters Laboratories (USA) up to temperatures of 50 to 105°C, depending on stress (category QMFZ 2, file no. E 42 337, Masterbatches are listed under category QMQS2, file no. E 93384).

Figures 47 to 50 show the change in some physical properties of Hostaform® POM C 9021 as a function of time and temperature when stored in hot air. The properties chosen were tensile strength and elongation at break. The test specimens (acc. to ISO 3167) were not under mechanical stress during the storage period.

The changes in properties are represented in two ways. **Fig. 47** shows the relative tensile strength as a function of storage time at 50, 80, 100 and 120 °C.

From this the very good aging resistance of Hostaform C 9021 temperatures up to 100° C can be seen. At 120 °C, the polymer starts to become brittle after about three months and, subsequently, the strength falls away relatively quickly.

In **Fig. 48**, the results from **Fig. 47** are reproduced in an Arrhenius diagram. The x-axis represents time on a logarithmic scale and the y-axis shows the reciprocal

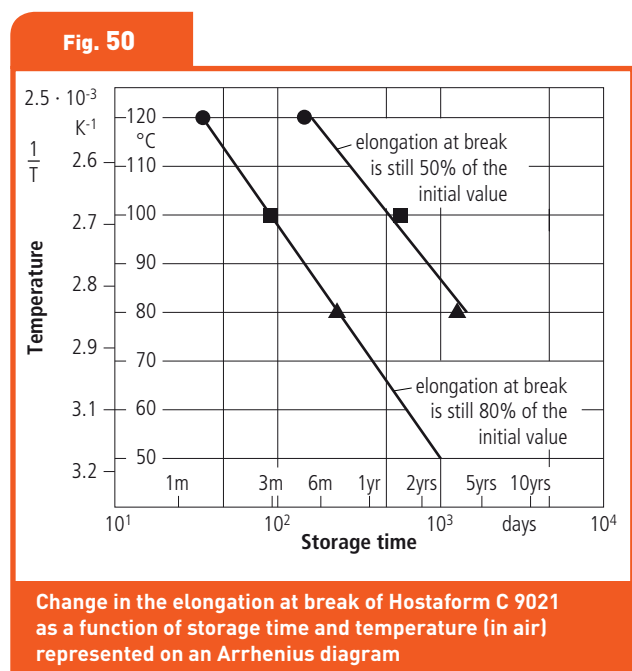
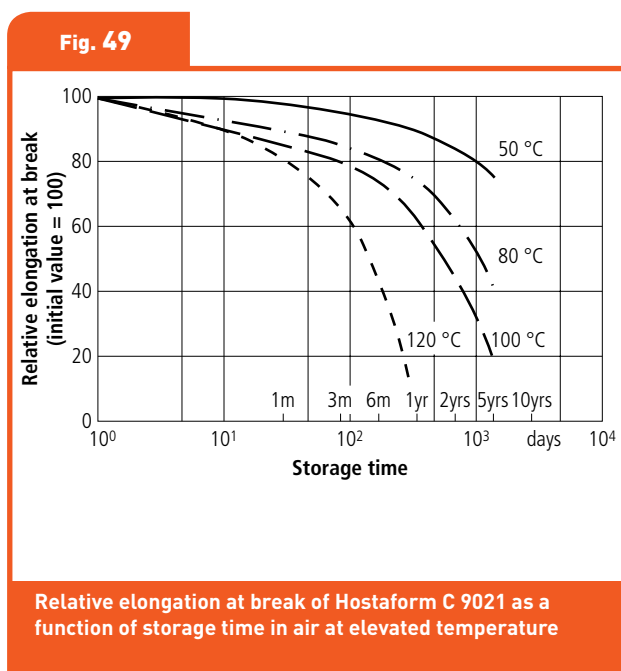
value of absolute temperature on a linear scale and the corresponding temperature scale in °C.

From this diagram, it is possible to determine the temperature a plastic can withstand for a certain period of time without a specified property value dropping below a specific limit value.

The bold line in **Fig. 48** gives the time/temperature combinations at which tensile strength starts to decline but is still > 60 N/mm<sup>2</sup>; this value was selected because it may be regarded as defining the start of embrittlement. At the points marked above the bold line on the 100 °C and 120 °C horizontals, tensile strength is still 80 % of the initial value.

In the case of Hostaform® POM, as with other thermoplastics, elongation at break is the property most influenced by temperature. A comparison of Figures 49 with 47, and of 50 with 48, shows that elongation falls away more rapidly than strength.

Generally, this Hostaform® POM C 9021 data is applicable to the other basic grades, the high-impact grades, and glass-fiber-reinforced Hostaform® POM, except for the elongation at break



results. The low-friction and special grades are of course not primarily intended for applications at elevated temperature.

## 4.2 Properties in water

### 4.2.1 Water absorption

Hostaform® POM has very low water absorption. The basic grades and most low-friction grades have values of appr. 0.1% after 24 hours and appr. 0.2% after 96 hours when tested at 20 °C.

The other grades have slightly higher values. The saturation value according to ISO 62 is between 0.12 and 0.25% at 23 °C and 50% relative humidity. Fig. 52 shows the water absorption of Hostaform® POM C 9021 as a function of time over the temperature range 20 to 100 °C. Even at a temperature of 100 °C, water absorption does not exceed about 1.6%.

The change in length of Hostaform® POM C 9021 due to saturation with water at various temperatures is shown in Fig. 53 (measured at room temperature).

Water absorption by Hostaform® POM is a reversible process, i.e., on subsequent storage in air, the absorbed water is given up again until equilibrium is reached.

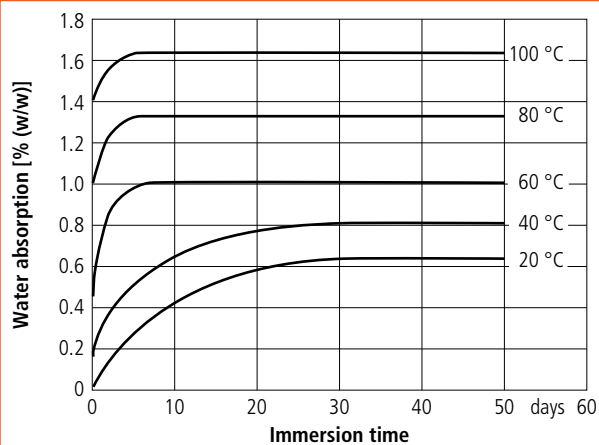
## 4.2.2 Service temperature in hot water

### 4.2.2.1 Hostaform basic grades

The high thermal stability which Hostaform® POM moldings exhibit in air is again evident in hot-water immersion tests. Figs. 54 and 55 show the changes with time in the tensile strength and elongation at break of Hostaform® POM 9021 on immersion in hot water at temperatures of 60, 80 and 100 °C.

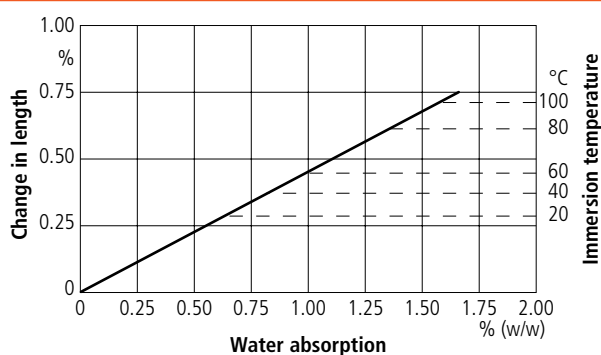
The minimal decline in these values shows clearly the resistance to hydrolysis achieved through the special chemical structure of Hostaform® POM. When Hostaform® POM C is heated to boil in a 1% detergent solution, the resultant change in properties is about the same as after boiling in water. The high aging-resistance in hot water, low water absorption and good resistance to detergent solutions make Hostaform® POM C a particularly suitable material for washing-machine and dishwasher components, and for kettles.

Fig. 52



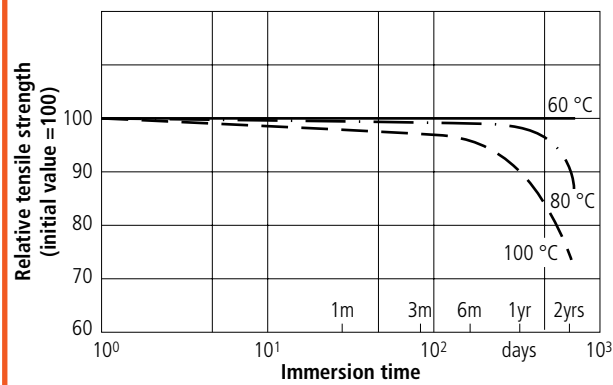
Water absorption of Hostaform C 9021 as a function of immersion time at various temperatures [ISO 62]

Fig. 53



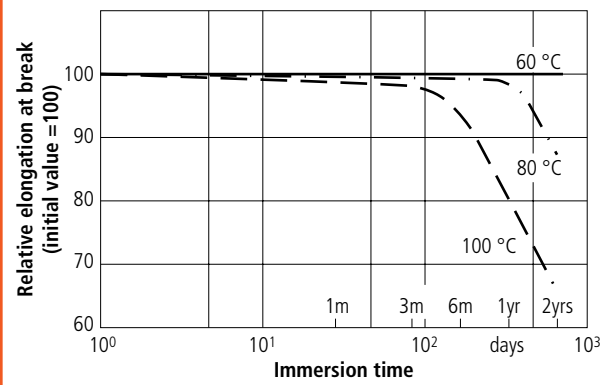
Change in length of Hostaform C 9021 as a function of water absorption

Fig. 54



Relative tensile strength of Hostaform C 9021 as a function of immersion time in hot water

Fig. 55



Relative elongation at break of Hostaform C 9021 as a function of immersion time in hot water

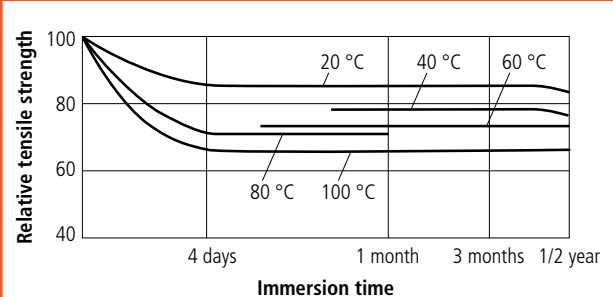
The test specimens which provided the data for Fig. 55 were not mechanically stressed during heat aging. For this reason, it is not possible to deduce from the results the suitability of a particular Hostaform® POM grade for an application involving mechanical stress, e.g., internally stressed components for sanitary engineering. The criterion for making such an assessment is creep strength as described in section 4.2.2.2. In addition, the disinfectants used in drinking water (e.g., ozone) must be taken into account, since they have an effect on creep strength depending on their concentration.

#### 4.2.2.2 Reinforced grades

Glass-fiber-reinforced Hostaform® POM exhibits a relatively rapid loss in tensile strength on contact with hot water and drops back to about the same level of strength as the basic grade Fig. 56.

During the further course of heat aging, glass-fiber-reinforced Hostaform® POM behaves like the unreinforced material, i.e., the initial decline in tensile strength is not attributable to degradation of the Hostaform® POM matrix; the thermal stability of the reinforced material is practically the same as that of the basic grade. The reason for the initial decline in tensile strength is rather that water attacks the glass fiber/Hostaform® POM interface.

Fig. 56

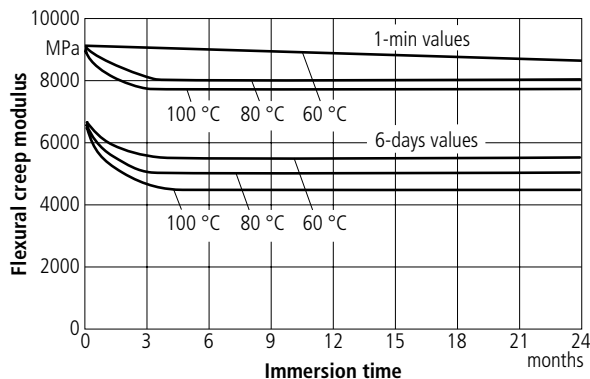


Properties of Hostaform C 9021 GV 1/30 in contact with water; relative tensile strength as a function of immersion time and temperature

In contrast to tensile strength, the flexural creep modulus of glass-fiber-reinforced Hostaform® POM shows only a slight initial decline on immersion in hot water and then remains at the same level; the extent of the decline is temperature-dependent Fig. 57.

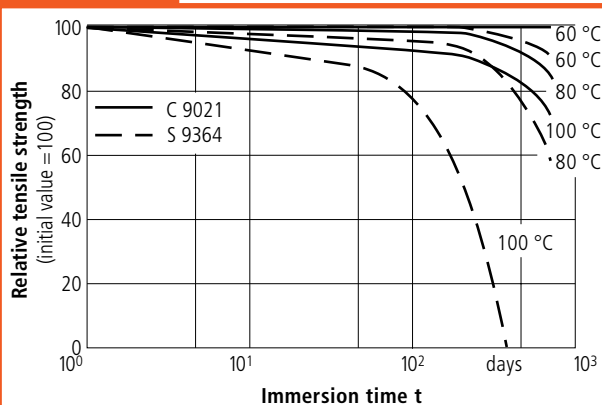
Glass-sphere-filled Hostaform® POM has only limited suitability for use in hot water but can be specially modified for this purpose; our Hostaform Research and Development Department will be pleased to give more detailed information on this.

**Fig. 57**



Properties of Hostaform C 9021 GV 1/30 in contact with water; flexural creep modulus as a function of immersion time and temperature

**Fig. 58**



Relative tensile strength of Hostaform C 9021 and S 9364 as a function of immersion time in hot water

#### 4.2.2.3 Hostaform/Elastomer blends

The high-impact Hostaform® POM grades have somewhat lower resistance to hot water than the basic grades. **Fig. 58** shows this using the example of the change in tensile strength over time. Hostaform® POM S 9364 and C 9021 on immersion in water at 60, 80 and 100 °C.

#### 4.2.3 Resistance to chlorinated drinking water

Hostaform® POM is already used for fluid handling in many drinking water applications. Hostaform® POM MR130ACS is supplied as a special grade with better resistance to chlorinated drinking water than the standard Hostaform® POM grade C 9021. This is shown by the results of the tests described below.

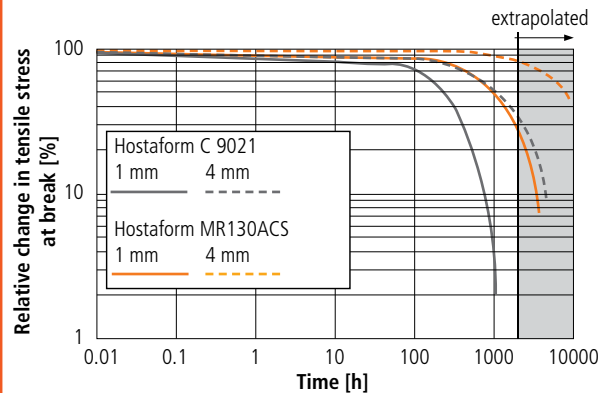
Hostaform® POM MR 130ACS and Hostaform® POM C 9021 were immersed stress-free in chlorinated water using the following test parameters:

- ▶ Medium: Chlorine solution with 10 mg/l free chlorine (chlorine bleaching solution)
- ▶ Temperature: 60 °C – controlled
- ▶ pH-Value: 6.5 – controlled
- ▶ Test duration: 2000 h

The chlorine concentration was held constant throughout the immersion period by adding chlorine. This complies with a regular drinking water supply in real applications.

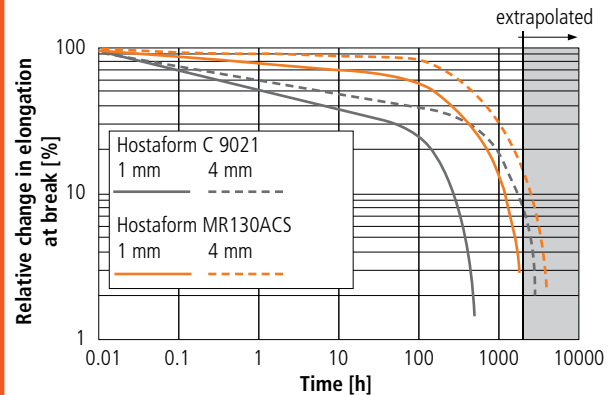
The results are shown in **Figs. 59a** (tensile stress at break) and 59b (elongation at break). The tests confirm the better resistance of Hostaform® POM MR130ACS to chlorinated water compared with Hostaform C 9021. This is even more pronounced at low wall thickness.

Fig. 59a



Relative change in the tensile stress at break of Hostaform C 9021 and MR130ACS after immersion in chlorinated water (60 °C / 10 mg/l chlorine concentration); ISO 527 A and 1/4 test bars (4mm / 1 mm wall thickness)

Fig. 59a



Relative change in the elongation at break of Hostaform C 9021 and MR130ACS after immersion in chlorinated water (60 °C / 10 mg/l chlorine concentration); ISO 527 A and 1/4 test bars (4mm / 1 mm wall thickness)

Orienting tests with a chlorine solution with 5 mg/l free chlorine (according to the WHO recommendations, Fig. 60 confirmed the test results.

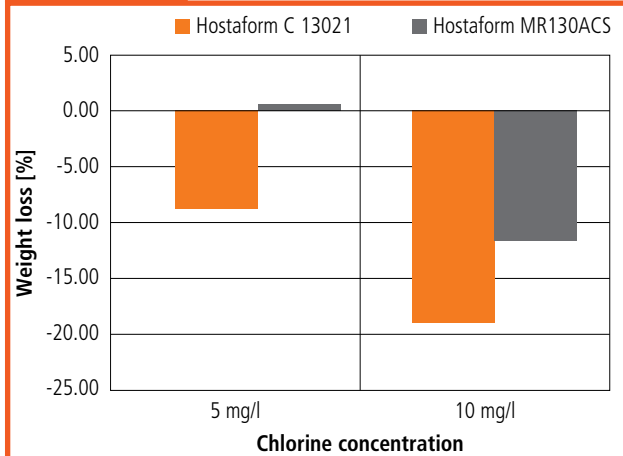
Compared to standard POM, Hostaform® POM MR130ACS also demonstrates a better resistance to highly active acidic cleaning agents. Further information is in the Product Information “Hostaform® POM MR130ACS in contact with highly active acidic cleaning agents and chlorinated drinking water,” ordering no. TI-BR1014E.

#### 4.3 Fuel resistance Hostaform® Standard Grades

Hostaform® POM standard grades are resistant to petrol, including fuels containing 15 to 20% ethanol or methanol. The chemical resistance data of the basic grades are given in Tab. 2. In addition to chemical resistance, the degree of swelling is an important factor in assessing the suitability of Hostaform® POM for use in contact with fuels.

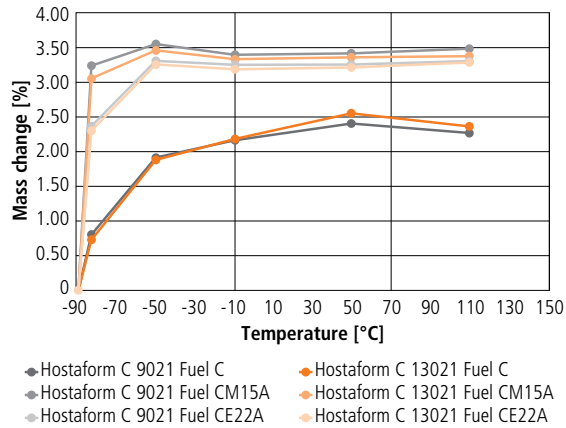
Fig. 61 shows the fuel absorption of the Hostaform® POM C 9021 and C 13031 in contact with Fuel C,

Fig. 60



Weight loss of Hostaform C 9021 compared to MR130ACS at 5 mg/l and 10 mg/l chlorine concentration after 2000 h immersion at 60 °C

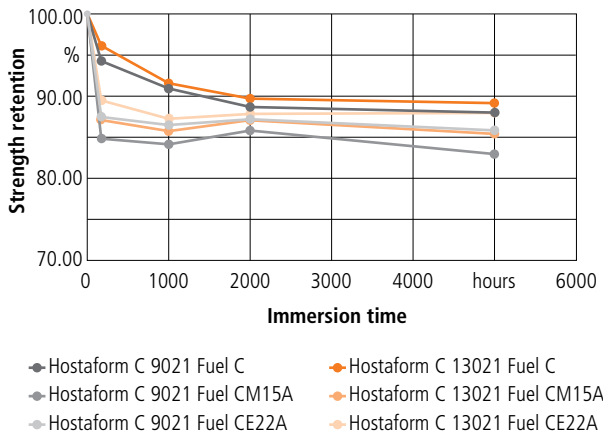
**Fig. 61**



**Mass change for Hostaform C 9021 and C13031 in Fuel C<sup>1</sup>, CM15A<sup>2</sup>, and CE22A<sup>3</sup> at 65 °C**

- <sup>1</sup> Equal volume mixture of toluene and iso-octane
- <sup>2</sup> 15% aggressive methanol by volume in Fuel C, where aggressive methanol is prepared blending 99.9% by volume methanol (having 0.174 wt% water) with 0.1% aggressive water for methanol; aggressive water for methanol prepared using 5 gm NaCl and 50 ml formic acid in distilled water to make 1 liter total volume.
- <sup>3</sup> 22% aggressive ethanol by volume in Fuel C, where aggressive ethanol is prepared blending 99.9% by volume ethanol (having 0.874 wt% water) with 0.1% aggressive water for ethanol; aggressive water for ethanol prepared using 5 gm NaCl and 52.7 ml formic acid in distilled water to make 1 liter total volume.

**Fig. 62**



**Strength retention for Hostaform C 9021 and C13031 in Fuel C, CM15A, and CE22A at 65 °C**

CM15A, and CE22A as a function of immersion time at 65°C (using biweekly fuel changes).

It should be noted that CM15A and CE22A are often considered “worst-case” oil surrogates for polymer material testing. Saturation is reached after approximately 1,000 hours (for 4mm-thick tensile bars) at an absorption level of about 2.0-3.5%. Mass change increases only slightly with the addition of aggressive methanol. The absorption process – as in the case of water – is reversible.

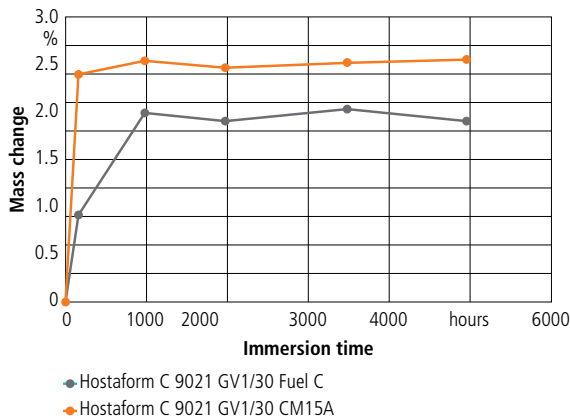
Tensile strength retention for Hostaform® POM C 9021 and C 13031 as a function of immersion time in Fuel C, CM15A, and CE22A is shown in Fig. 62. Again, in all cases, the immersion was done at 65°C with biweekly fuel refreshing.

Noticeably, both Hostaform® POM C 9021 and C 13031 show excellent strength retention, even when exposed to methanol containing fuels for 5,000 hours.

### Hostaform Reinforced Grades

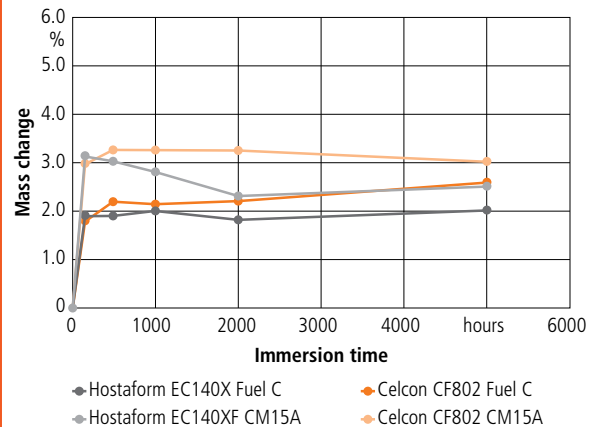
As is the case for the basic grades, the Hostaform® POM matrix of the glass-fiber-reinforced grades is not chemically attacked by fuels. And the only effect is a slight swelling. However, contact with fuels – as with water – brings an initial decline in tensile strength due to attack on the glass fiber/Hostaform® POM interface. The rate of this decline is temperature and time-dependent. When this initial phase of decline is complete, the fuel causes no further loss in tensile strength.

**Fig. 63a**



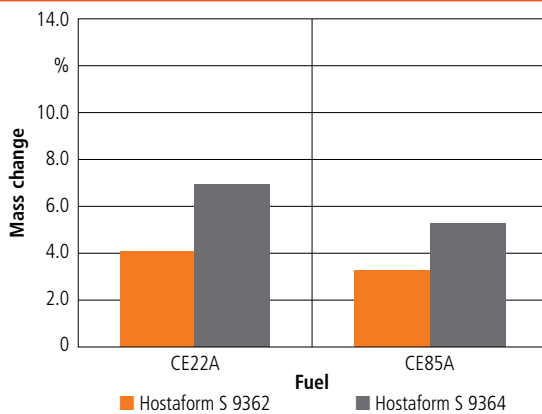
Mass change for Hostaform C 9021 GV1/30 in Fuel C and CM15A at 65 °C

**Fig. 64a**



Mass change for Hostaform ESD grades in CM15A at 65 °C

**Fig. 63b**



Impact modified Hostaform mass change results after 56 days exposure to ethanol-containing fuels at 65 °C

**Fig. 63a** shows the swelling mass change upon exposure to both Fuel C and CM15A at 65°C with biweekly fuel refreshing. After 5,000 hours exposure there is only minimal swelling, with most of the swelling reached after the initial 168 to 1,000 hours

#### Hostaform® POM Impact Modified Grades

Impact-modified Hostaform® POM grades, by definition, are more flexible than standard grades; this increased flexibility results in slightly different

fuel immersion behavior. The changes in weight of impact for grades Hostaform® POM S 9362 and S 9364 after 56 days immersion at 65 °C in CE22A and CE85A are shown in **Fig. 63b**. The slightly higher weight increase with the test fluids needs to be taken into account in component design.

#### Hostaform® POM Electrostatic Dissipative (ESD) Grades

Electrostatic dissipative (ESD) grades of Hostaform® POM are able to mitigate electrical charge build by providing a conductive pathway to ground.

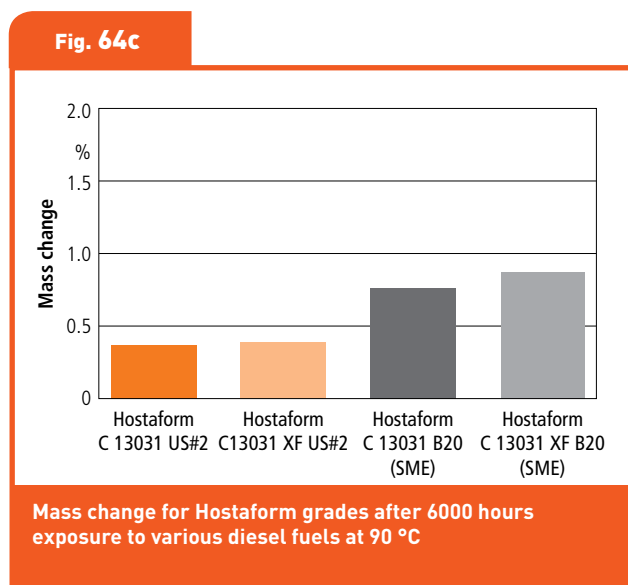
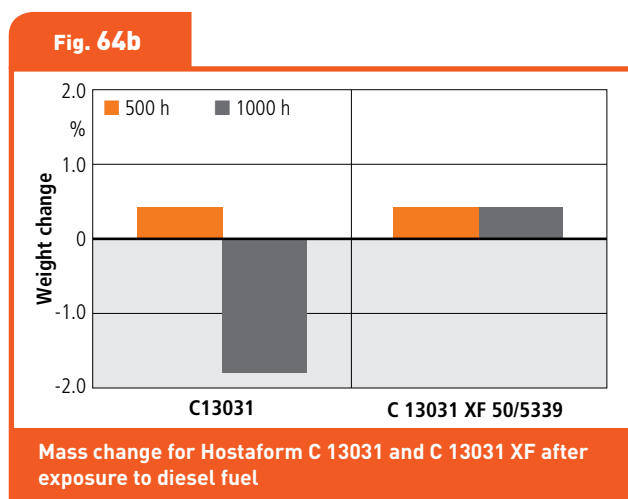
**Fig. 64a** shows mass change for Hostaform® POM EC140XF and Celcon® POM CF802 during exposure to CM15A at 65°C. Note that fuel was refreshed every two weeks.

#### Hostaform® POM Diesel Grades

The introduction of diesel direct-injection systems has led to a significant rise in fuel system temperature. As a result, the diesel is aged by the high temperatures of over 100°C and can produce aggressive decomposition products. To meet these demanding requirements, Celanese has developed Hostaform® POM grades that are more resistant to hot diesel: Hostaform® POM C 13031 XF 50/5339 and the electrically conductive grade Hostaform® POM EC140XF.

**Fig. 64b** shows the weight change in Hostaform® POM C 13031 XF 50/5339 compared with Hostaform® POM C 13031 after immersion in Haltermann test diesel at 100°C.

Additionally, Hostaform® POM C 13031 and C 13031 XF were immersed in US#2 ultra-low sulfur diesel (nominal 15 ppm sulfur) and derivatives at 90°C for 6000 hours using weekly fuel refreshes. Mass change results for both the US#2 and biodiesel blends (B20 using soybean methyl esters) are given in **Fig. 64c**. Soybean methyl ester (SME) addition slightly increases mass uptake after 6000 hours immersion at temperature, but all mass change levels appear quite moderate.

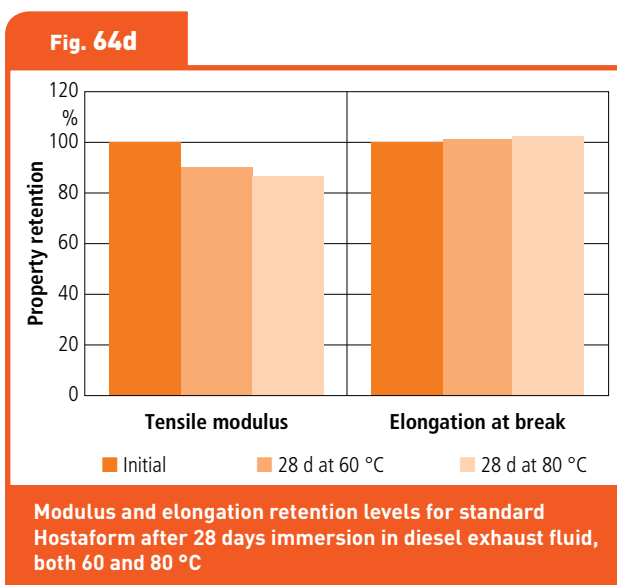


Before any of these grades are used, it is essential to conduct practical trials because the aging behavior of diesel fuel in a running engine is not defined.

#### 4.3.1 Diesel Exhaust Fluid (DEF also called AdBlue®)

Diesel exhaust fluid (DEF) is a highly pure aqueous urea solution used as a NOx reduction agent in SCR technology (selective catalytic reduction). The ammonia generated by the DEF reduces dangerous nitrogen oxides – which contribute to the greenhouse effect – into harmless nitrogen. In modern diesel vehicles, DEF is injected from an extra tank. The quality requirements for AdBlue® are specified in DIN 70070 and the associated test methods are specified in DIN 70071 – and both of these are covered additionally through ISO 22241-1 and -2. Exceeding these limit values can cause irreparable damage to the catalytic system.

Hostaform® POM polyacetals – including C 9021, C 2521, and C 13031 – were tested for chemical compatibility with AdBlue® over 28 days at both 60 and 80 °C. After storage, the AdBlue® solution retained purity and composition, thereby satisfying the purity requirements in the DIN and ISO standards. Additionally, modulus and elongation at break-retention values were tested for the Hostaform grades after 28 days exposure at both 60 and 80 °C. Figure 64d shows retention values are excellent, >85% retention of modulus and >100% elongation at break.



## 4.4 Chemical properties

### 4.4.1 Chemical resistance

#### 4.4.1.1 Hostaform basic grades

The Hostaform® POM basic grades have high resistance to many organic and inorganic chemicals. Very few solvents are known which can dissolve the material below its crystalline melting point. One of these is hexafluoroacetone sesquihydrate. Hostaform® POM withstands strong alkalis (for example 50% NaOH), even at high temperatures, but is attacked by oxidizing agents and strong acids (pH < 4). The data is shown **Tab. 2**.

Generally speaking, Hostaform® POM is not prone to environmental stress cracking.

**Tab. 2**

Chemical resistance of the Hostaform basic grades

resistant +	limited resistance /	not resistant -
weight increase < 3%	weight increase 3 to 8%	weight increase > 8%
or	or	or
weight loss < 0.5%	weight loss 0.5 to 3%	weight loss > 3%
and/or	and/or	and/or
decrease in tensile strength < 15%	decrease in tensile strength 15 to 30%	decrease in tensile strength > 30%

The results were determined after a test period of 60 days on 1 mm-thick test specimens injection molded from Hostaform® POM C 9021. During the tests, the specimens were not under external stress.

The quoted ratings apply to all Hostaform® POM basic grades. The reinforced and S grades may deviate from these in individual cases.

Substance	20 °C	60 °C
acetic acid (10%)*	+	+
acetic acid (80%)	/	-
acetone	+	/
acetylene tetrabromide	/	-
ammonia (10%)	+	+
ammonia, conc.	+	+
ammonium sulphate (10%) (pH 5.8)	+	-
benzene	/	/
benzene with 15 to 20% methanol	+	+
butanol	+	+
butyl acetate	+	/
butyraldehyde	/	/
butyric acid (1%)*	+	+
butyric acid (98%)	/	/
calcium ammonium nitrate	+	+
calcium chloride (10%)	+	+
calcium nitrate (10%) (pH 6.4)	+	+
cananga oil	+	+
carbon disulphide	+	+
carbon tetrachloride	+	/
chlorobenzene	/	/
chloroform	-	-
chromic acid (3%)	/	/
citric acid (10%)*	+	-
Clophen® A 60 (Bayer)	+	+
coffee (Nescafé®)	+	+
Complezal® Typ Blau 12 + 12 + 17 + 2 (10%, pH 5.8)	+	+
Complezal® Typ Gelb 15 + 15 + 15 (10%, pH 5.8)	+	+
Complezal® Typ NP 20 + 20 + 0 (10%, pH 5.7)	+	+
Complezal® Typ Rot 13 + 13 + 21 (10%, pH 5.4)	+	+
copper sulphate (10%)	+	+
developer solution 1:100 (pH 10.4) (Rodinal® Agfa)	+	+
developer solution 1: 50 (pH 10.9) (Rodinal® Agfa)	+	+
dibutyl phthalate	+	+
diesel oil	+	+
dimethyl phthalate	+	/
dioctyl sebacate	+	+
dioxane	/	/
engine oil BP HP 20	+	+
engine oil SAE 40 (Caltex)	+	+
ethanol (96%)	+	+
ether (DAB 6)	+	+
ethyl acetate	/	/
ethyl chloride (DAB 6)	+	/

Substance	20 °C	60 °C
ethyl glycol	+	/
ferric chloride (10%)	/	-
fixing bath solution (pH 5.4)	+	/
fluorocarbons (partially halogenated)	-	-
fluorocarbons (perhalogenated)	+	+
formaldehyde (40%)	+	+
formic acid (10%)*	+	-
fuel oil EL	+	+
galbanum resin	+	-
Genantin®/tap water 1:1 (+ 1% Donax® C, Shell)	+	
glacial acetic acid	/	-
glycerol	+	+
glycol/distilled water 48:52	+	+
Grisiron® GBF 1 (5 g to 100 g H <sub>2</sub> O)	+	+
hydrochloric acid (10%)	-	-
hydrogen peroxide (30%)*	+	-
hydroxycitronellal	+	+
ink (Pelikan® ink, blue-black)	+	-
isopropyl alcohol	+	+
jet fuel JP 1 (Shell)	+	+
jet fuel JP 4 (Shell)	+	+
lactic acid (10%)*	+	/
lactic acid (90%)*	+	-
lavender oil, highest-quality	+	+
lemongrass oil	+	+
lime, chlorinated (approx. 10%)	-	-
methanol	+	+
methyl acetate	/	/
methyl bromide	-	-
methyl ethyl ketone	/	/
methyl glycol	/	/
methyl glycol acetate	/	-
methyl isobutyl ketone	+	+
methyl isopropyl ketone	+	+
methylene bromide	-	-
methylene chloride, technical	-	-
mineral oil	+	+
Mobil® oil SAE 20	+	+
Mobil oil HD SAE 20 after 3000 km	+	+
n-hexane	+	+
natural gas	+	+
nickel sulphate (10%)	+	+
nitric acid (10%)	-	-

Substance	20 °C	60 °C
nitrogen phosphate (10%) (pH 5.1)	+	+
nitrous gases	-	-
oil of cloves	+	
olive oil	+	-
ozone	-	-
peat water (pH 3.7)	+	+
perchloroethylene	+	-
Persil® 59 (5%) (Henkel)	+	+
petrol, standard-grade	+	+
petrol/benzene mixture (super-grade petrol)	+	+
petroleum	+	+
petroleum fraction (boiling point 100-140 °C)	+	+
phenol	-	-
phosphoric acid (25%)*	+	-
potassium hydroxide (caustic potash solution)	+	+
potassium permanganate (10%)*	+	+
rape oil nethyl ester	+	+
refrigerant R 134 a (System Reclin)	+	+
sea water (North Sea)	+	+
sodium bicarbonate (10%)	+	+
sodium bisulphite liquor (pH 4.5)	-	-
sodium carbonate (10%)	+	+
sodium chloride	+	+
sodium hydroxide (caustic soda solution)	+	+
sodium hypochlorite (bleaching solution, about 12.5% active chlorine)	/	-
sodium nitrate Hoechst® (10%) (pH 8.8)	+	+
sodium orthophosphate, monobasic (10%)	+	+
sodium orthophosphate, dibasic (10%) +	+	+
sodium orthophosphate, tribasic (10%) +	-	+
soya bean oil	+	+
sulphur dioxide gas	-	-
sulphuric acid (10%)*	+	-
sulphuric acid (50%)	-	-
tetrahydrofuran	/	/
Tetralin® (Henkel)	+	/
thiophene	/	/
toluene	+	+
transformer oil (Univolt® 36, Esso)	+	+
trichloroethylene	/	/
urine	+	+
water, distilled	+	+
xylene	+	+

\* Because of the acid or oxidizing nature of these chemicals, trials are recommended before prolonged contact with Hostaform® POM.

#### 4.4.1.2 Reinforced grades

The resistance ratings shown in **Tab. 2** apply to the polymer matrix. Since glass itself may be regarded as having adequate inertness to the chemicals listed there, the ratings given in the table may be deemed to apply to the reinforced grades as well. As already mentioned, however, the tensile strength of glass- fiber-reinforced Hostaform® POM declines in contact with water or fuels; in fact this loss is apparent not only with the two media mentioned but with liquid media in general. Change in tensile strength is one of the rating criteria. If these criteria were to be strictly applied, glass-fiber-reinforced Hostaform® POM would have different ratings. However, this only needs to be taken into account in applications where full retention of tensile strength is an essential requirement.

#### 4.4.1.3 Hostaform/Elastomer blends

Both components of Hostaform® POM S, i.e., the matrix and the elastomer, contribute proportionally to its chemical resistance, which is why only generalizations are possible.

Hostaform® POM S 9363/64 are resistant to fuels, i.e., nonpolar hydrocarbons, but have only limited or no resistance to methanol, i.e., polar solvents; in addition to alcohols, this group includes ketones and esters. The behavior of the above grades in water is described in section 4.2.2.

Hostaform® POM S 9243/44 XAP<sup>2</sup> are swollen by fuels and their toughness declines somewhat with immersion time; they are, however, resistant to diesel. In contact with methanol, swelling is slight, but again, a decline in toughness occurs.

Our Hostaform® POM Research and Development Department will be pleased to give further information.



#### 4.4.2 Gas and vapor permeability

The permeability of containers made from the Hostaform® POM basic grades to air and other gases is very low compared with values for other thermoplastics. These grades also have very low permeability to aliphatic and halogenated hydrocarbons.

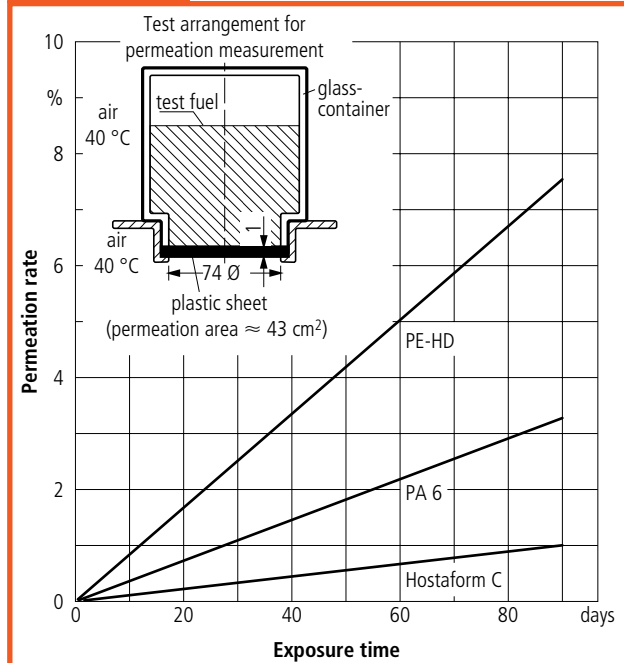
The following permeability values were measured on 0.08 mm-thick film with a density of 1.405 g/cm<sup>3</sup> at 23 °C:

▶ Oxygen:	49 cm <sup>3</sup> (0 °C, 1 bar) m <sup>2</sup> · d · bar
▶ Carbon Dioxide:	1110 cm <sup>3</sup> (0 °C, 1 bar) m <sup>2</sup> · d · bar
▶ Water Vapor:	32 g/m <sup>2</sup> · d (with a moisture gradient of 85%), on 3-mm thick sheets at 23 °C
▶ Helium:	7.0 cm <sup>3</sup> /m <sup>2</sup> · d · bar

An internal test conducted by Celanese to determine permeability to oil **Fig. 65a** showed very low values for Hostaform® POM C compared with those for PA 6 and PE-HD. The tests were carried out on 1-mm thick sheets at 40 °C. The dependence of oil vapor permeability (super, unleaded) on temperature is shown in **Fig. 65b**.

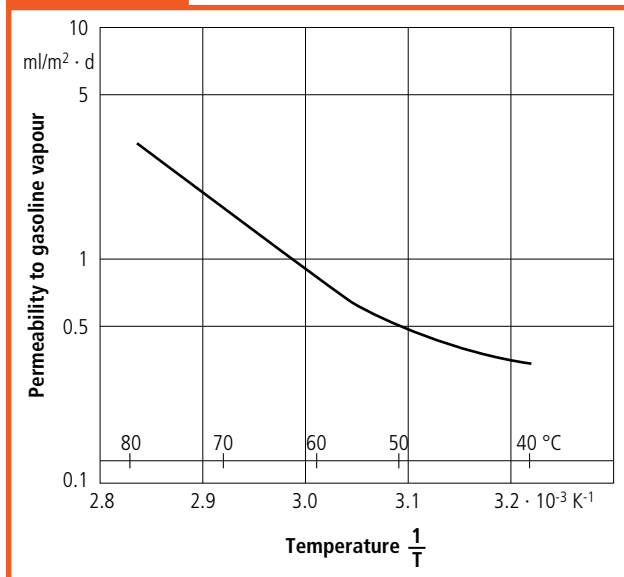
According to tests carried out by the Institut für Gastechnik, Feuerungstechnik und Wasserchemie (Institute for Gas and Fuel Engineering and Water Chemistry) at the University of Karlsruhe, Hostaform® POM is resistant to fuel gases and therefore suitable for use in the manufacture of gas fittings. As numerous storage tests have shown, Hostaform® POM C is also very suitable for the production of aerosol containers requiring high mechanical strength, chemical resistance and aromaseal properties. In selecting products to fill these containers, the relatively high water vapor permeability of Hostaform® POM should be taken into account.

**Fig. 65a**



Permeability to oil of Hostaform C and other thermoplastics as a function of exposure time (test fuel M 15, test temperature 40 °C)

**Fig. 65b**



Permeability of Hostaform C 27021 to oil vapor as a function of temperature (test fuel super, unleaded, wall thickness 1.22 mm)

## 4.5 Resistance to light and weathering

### 4.5.1 General

Polyacetals – like most other polymers – do degrade over a period of time by exposure to weathering. The primary agent is ultraviolet (UV) radiation. This initially causes surface crazing (micro-crack formation), which leads to more severe surface chalking characterized by the surface turning white. These surface changes will result in a loss of gloss as well as a deterioration in mechanical properties. The thinner the wall thickness, the more rapidly these effects occur. The behavior of the unstabilized Hostaform® POM C grades on exposure to natural and accelerated weathering is described in [5]. Most importantly, effective light-stabilizer systems have long been available for Hostaform® POM and are continually being further developed and optimized.

Please note that color difference data presented in this section were calculated using illuminant D<sub>65</sub>, 10° observer, specular included, and expressed in CIELab units.

### 4.5.2 UV Test Methods

#### 4.5.2.1 Natural Weathering

There are many UV test methods, both natural and artificial, used to evaluate the long-term performance of plastic materials when exposed to such energy. Natural exposure is performed outdoors in various climates. These can be in central Europe, southern Europe, south Florida or Arizona. Natural weathering can either be under glass or direct weathering with no glass, so that the plastic part is exposed to all of the weathering elements such as rain. Under-glass exposure is generally used to simulate interior applications such as automotive interior or office environments, whereas direct exposure is used to simulate exterior automotive applications or other general purpose outdoor applications such as irrigation parts. Natural exposure is considered accelerated

exposure as the parts are exposed continuously to the sun. Under-glass exposure can be further accelerated by the use of mirrors to concentrate the sunlight, tracking boxes to follow the trajectory of the sun, and the use of closed weathering boxes with or without temperature control. The type of glass also affects the amount of UV energy that the plastic receives. Under-glass exposure is generally conducted at a 45° angle facing south in the Northern Hemisphere. Direct exposure is accelerated by generally exposing samples at a 5° angle facing south.

#### 4.5.2.2 Artificial Weathering

Artificial weathering is the use of laboratory equipment to simulate exposure in the final application, for example, office environments, parts behind glass, interior automotive, irrigation or exterior automotive. The most common laboratory device is the Xenon arc weatherometer. Sunshine Carbon arc devices are also used, but UV energy output is not controlled or as consistent as the Xenon lamp. Enclosed Carbon arc devices are no longer used. Fluorescent/condensation devices such as the QUV test are generally not recommended for plastics and are typically used for paints and coatings.

There are many test methods available when using artificial weathering. Key parameters of these methods include inner and outer filter combinations, the irradiation amount and wavelength it is controlled at, light on/light off cycle, water spray cycle (if any), and, with each light or dark cycle, the black each light or dark cycle, the black panel or black standard temperature and the relative humidity. For these variables, it is important to ensure that all of them are defined when comparing test results. Furthermore, one must use caution when trying to compare results between two different test methods. This is often sometimes impossible as degradation mechanisms can be different depending on the specific method employed.

For office environments, consumer electronics, and other interior applications (not automotive), ASTM D4459 is usually specified with relatively low temperature, low UV energy and no water spray. For automotive interior applications, DIN EN ISO 105-B06 (PV1303) is generally used for Europe, whereas as SAE J2412 or Ford FLTM B0116-01 are used in North America. OEMs in other regions may have specific methods, but they are generally based on one of these standards. For outdoor applications including exterior automotive, SAE J2527 is typically used with non-automotive applications requiring less exposure time than automotive applications. Ford has a modified J2527 method while VW has two methods (PV3929 and PV3930).

#### 4.5.3 UV Stabilized grades

Most polymers are typically stabilized with a combination of UV absorbers, hindered amine light stabilizers and thermal stabilizers to protect against the degrading effects of UV energy. Hostaform<sup>®</sup> POM is no different. With the combination of various test methods previously discussed and the breadth of application space for Hostaform<sup>®</sup> POM, it is not surprising that there are a number of light-stabilized grades of Hostaform<sup>®</sup> POM optimized for the specific application and stability requirements. Each grade contains an optimized stabilization system to meet or exceed the requirements based on natural or artificial weathering requirements. Typical grades would be Celcon M-UV series (i.e., M90UV) for non-automotive applications (primarily natural and light colors), “LS” series (i.e. C9021 LS) and UV-Z series (i.e., UV90Z) for automotive interior and general purpose applications, and LS 10/1570 series (i.e., C9021 LS 10/1570) and “WR” series (i.e., WR90Z) for outdoor and exterior automotive applications.

UV-stabilized grades are commonly used in a range of colors. Colorant selection is equally important to achieving a UV-stabilized system that maintains properties and retains its original color. **Tab. 4.5.1** shows progression of improved performance starting with a conventional resin without UV-stabilizers,

**Tab. 4.5.1**

Color Change after Exposure Test Method: SAE J2412, Test Length: 1,240.8 kJ/m <sup>2</sup>		
UV Package	Colorants	Total Color Difference (DE*)
None (C 9021 or M90)	UV stable	23.30
C9021 LS or UV90Z	Not UV stable	8.23
C9021 LS or UV90Z	UV stable	0.46

Target performance < 3.00

a colorant system with poor UV performance, and the optimized system with both UV-stabilizers and effective pigmentation. Celanese has a broad range of colors available in UV-stabilized resins, with custom colors made available upon request. It is important to note that the use of a UV-stabilized natural resin with a color masterbatch supplied from a third party may not yield the performance level required for the application. Celanese has the expertise to optimize both the UV-stabilization system and the colorant package to ensure maximum performance under UV conditions.

##### 4.5.3.1 UV Stabilized grades for interior applications

Many Hostaform<sup>®</sup> POM grades have been UV-stabilized for use in interior applications. All grades, including general purpose grades such as M-UV series and all LS and UV-Z series, can be used in office environments and other environments requiring low-to-moderate indoor UV exposure. The most demanding interior application is automotive interior. Typical grades are C 9021 LS, UV90Z, and low-gloss UV140LG, along with their low-emission versions. Other melt-flow versions and specialty grades are also available. Grades optimized for automotive interior applications meet automotive OEM interior requirements in a wide range of colors supplied by Celanese. Typical test methods and exposure levels are listed in **Tab. 4.5.2**. Data for specific colors as examples are shown in **Tab. 4.5.3** for test method SAE J2412.

**Tab. 4.5.2**

**Hostaform Performance in Typical Interior Automotive Test Methods.  
Optimized Grades: C9021 LS, UV90Z, UV140LG, etc.**

OEM	Test Method	Exposure	Color Difference (DE*)	Visual Rating AATCC GrayScale
VW	PV1303	Up to 10 cycles	< 1.5	4 or higher
General Motors	SAE J2412	1,240.8 kJ/m <sup>2</sup>	< 1.0	4 or higher
Ford	FLTM B0116-01	3,609.6 kJ/m <sup>2</sup>	< 1.0	4 or higher
Chrysler	SAE J2412	1,240.8 kJ/m <sup>2</sup>	< 1.0	4 or higher
Toyota	TSL0601G	1,000 hrs	< 1.5	4 or higher
Honda	HES D6601	800 hrs	< 1.0	4 or higher

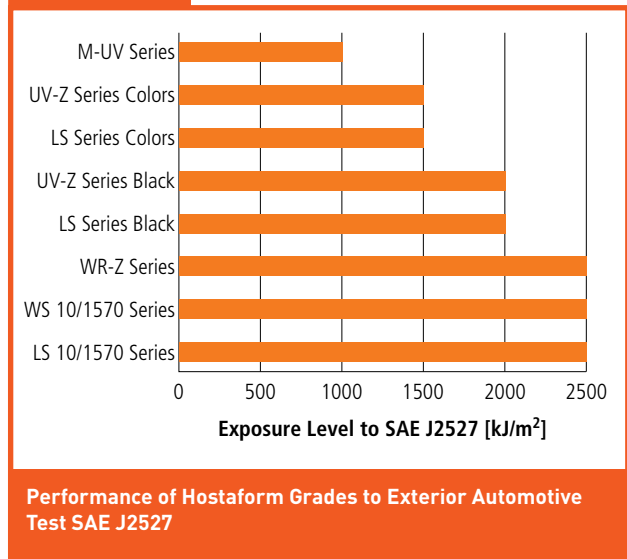
**Tab. 4.5.3**

**Color Change after Exposure  
Test Method: Interior Automotive SAE J2412,  
Test Length: 1,240.8 kJ/m<sup>2</sup>**

Color	DL*	Da*	Db*	DE*
Light Gray	+0.44	-0.13	+0.24	0.52
Medium Gray	+0.33	-0.07	+0.16	0.37
Dark Gray	+0.15	-0.38	+0.50	0.64
Tan	+0.25	+0.04	+0.10	0.27
Brown	+0.34	-0.13	+0.13	0.39
Blue	+0.19	-0.21	+0.29	0.40
Green	-0.01	-0.08	+0.22	0.24
Red	+0.14	+0.67	-0.08	0.69
Black	+0.27	-0.07	-0.23	0.36

Target Performance DE\* < 3.0

**Fig. 4.5.1**



#### 4.5.3.2 UV-Stabilized grades for Outdoor Applications

UV-Stabilized grades of Hostaform® POM have been used in exterior applications such as irrigation parts, cable ties, and exterior automotive components. For nonautomotive applications, exterior UV requirements vary widely by application. Artificial weathering requirements, if called out at all, typically use ASTM G155 Cycle #1 (commonly referred to as the Miami Cycle) or automotive exterior method SAE J2527, even for nonautomotive parts.

General-purpose Hostaform® POM UV grades of the M-UV series can be used for many nonautomotive exterior parts requiring some degree of outdoor UV protection. For additional UV protection, LS or UV-Z series products should be used. For the maximum UV protection, particularly for automotive exterior applications, weatherable grades of Hostaform® POM should be used and include the LS 10/1570 series, the WS 10/1570 series and the WR-Z series. The relative performance of each of these grades using exterior automotive test SAE J2527 is shown in **Fig. 4.5.1**

**Tab. 4.5.4**

Color Change after Exposure  
 Test Method: Exterior Automotive SAE J2527,  
 Test Length: 2,500 kJ/m<sup>2</sup>

Grade	DL*	Da*	Db*	DE*
C9021 LS 10/1570	-0.56	-0.08	-0.54	0.78
WR90Z CD32403	-0.64	-0.13	-0.45	0.79
WR140LG CD34682	-1.79	-0.04	-0.28	1.81
S27072WS 10/1570	+1.54	+0.03	-0.31	1.57

Target Performance DE\* < 3.0

**Tab. 4.5.5**

Color Change after Exposure  
 Test Method: Ford Modified Exterior Automotive  
 SAE J2527

Grade	Hours	DL*	Da*	Db*	DE*
WR90Z	1,000	-0.12	0.00	-0.21	0.24
CD32403	2,000	+0.07	+0.01	-0.20	0.21
	3,000	-0.07	0.00	-0.40	0.40

**Tab. 4.5.6**

Mechanical Property Retention after Exposure  
 Test Method: Exterior Automotive SAE J2527,  
 Test Length: 2,500 kJ/m<sup>2</sup>

Property	WR90Z CD32403
Tensile Stress	103.6 %
Notched Impact Strength	104.2 %

**Tab. 4.5.7**

Color Change after Exposure  
 Test Method: SAE J1976, 2-year Direct Exposure  
 South Florida, 5° South, Open Back Rack

Grade	DL*	Da*	Db*	DE*
WR90Z CD32403	-0.59	-0.16	+0.49	0.78
WR270Z CD32403	-0.89	+0.14	-0.20	0.92
S27072WS 10/1570	+1.99	-0.04	-0.73	2.45

Target Performance DE\* < 3.0

**4.5.3.2.1 Weatherable Grades for Exterior Automotive**

Weatherable Hostaform® POM grades have been specially formulated for exterior automotive applications. These grades available in black colors include the LS 10/1570 series, the WS 10/1570 series and the WR-Z series. These grades are designed to meet exterior automotive test method SAE J2527 with an exposure level of 2,500 kJ/m<sup>2</sup>. In addition, these grades typically meet other OEM specific methods such as VW PV3929 (Kalahari Method), VW PV3930 (Florida Method), or the Ford modified J2527 method. **Tab. 4.5.4** shows data for typical grades when exposed to SAE J2527 for 2,500 kJ/m<sup>2</sup>. Samples were washed after exposure but not polished.

Testing weatherable Hostaform® POM grades to specific OEM methods also shows exceptional performance. **Tab. 4.5.5** shows exposure data to the Ford-modified J2527 method. This method uses an inner/outer filter combination of borosilicate/ borosilicate with the normal operating conditions of

J2527. WR90Z was tested and performed extremely well out to 3,000 hours of exposure.

Mechanical property retention after exposure can also be a concern. Weatherable Hostaform® POM grades will give maximum mechanical property retention after exposure in outdoor applications.

**Tab. 4.5.6** shows mechanical property retention of WR90Z when exposed to exterior automotive test SAE J2527. This grade exhibits 100% retention of tensile and impact properties after 2,500 kJ/m<sup>2</sup> exposure. Other weatherable Hostaform® POM grades are expected to perform in a similar manner.

Direct exposure is also typically performed on materials used for exterior automotive applications. A typical test is SAE J1976 which requires 2 years direct exposure in South Florida, facing 5° South (almost horizontal), with an open back rack. Data for standard WR-Z series and impact modified, weatherable WS 10/1570 series is shown in **Tab. 4.5.7**.

#### 4.6 Resistance to high-energy radiation

Moldings made from polyacetals should not be used where the total radiation dose exceeds about  $3 \cdot 10^4$  J/kg. At higher exposure levels, moldings become discolored and brittle.

**Fig. 70** shows stress-strain curves for Hostaform® POM C at various dosage levels. It can be seen that tensile stress at yield remains practically constant up to a dose of  $2.5 \cdot 10^4$  J/kg, whereas the increasing brittleness of the test specimens is particularly evident in the decline in elongation.

When sterilizing plastic vessels and containers with ionizing radiation, a dose of  $2.5 \cdot 10^4$  J/kg is used. This dose alters the strength of Hostaform® POM C only minimally but through degradation reactions it leads to an appreciable decrease in elongation at break **Fig. 70** and hence also toughness. For this reason, and to avoid the risk of uncontrolled exposure to higher doses, superheated steam or ethylene oxide should be used in preference to gamma radiation for the sterilization of Hostaform® POM.

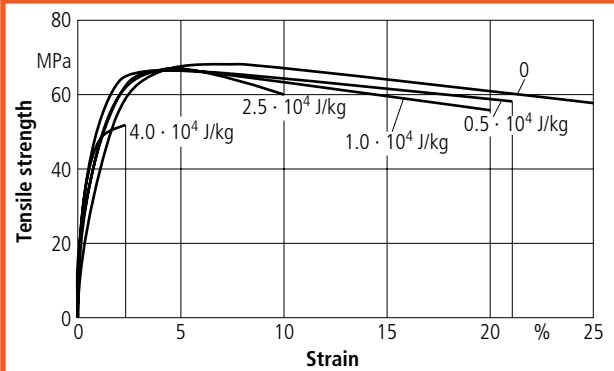
#### 4.7 Flammability

Polyacetals ignite on exposure to flame, continue to burn with a pale blue flame when the ignition source is removed and drip as they burn. When extinguished or if they continue to smolder, they give off acrid-smelling formaldehyde.

According to the UL 94 flammability test, Hostaform® POM is classified as "HB." It is not possible to produce formulation with vertical classification.

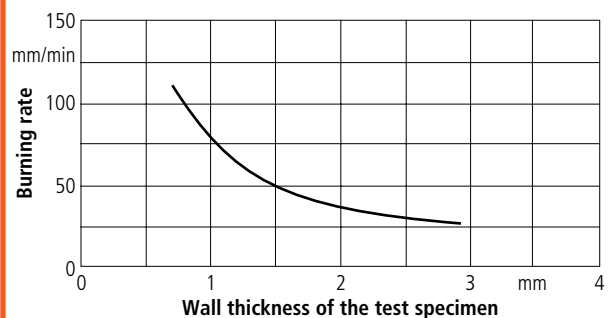
The burning rate determined on Hostaform® POM sheet >1 mm thick is below the maximum allowed by FMVSS 302 **Fig. 70a**.

**Fig. 70**



Stress strain curves for Hostaform C as a function of radiation dose

**Fig. 70a**



Burning rate of Hostaform C according to FMVSS 302, as a function of specimen wall thickness



## 4.8 Regulatory Status

### Suitability for applications coming into contact with food – EU Regulations

Generally speaking, there are no objections to the use of plastics materials in contact with food, provided the plastic material complies with regulation Framework regulation EU 1935/2004 (all materials),

- ▶ Regulation EU 2023/2006 on good manufacturing practice for materials and articles intended to come into contact with food (GMP)
- ▶ Regulation EU 10/2011 on plastic materials and articles intended to come into contact with food (also called PIM – Plastics Implementation Measure)
- ▶ Migration of substances from the article into the food does not exceed the limits specified in Annex I of EU 10/2011
- ▶ The articles are suitable for the intended use
- ▶ The finished products do not impart odor or taste to the food

National legislations may still apply for colorants. In Germany this would be BfR (German Institute for Risk Assessment) recommendation IX “Colorants for the coloration of plastics and other polymers for consumer articles.”

### Suitability for applications coming into contact with food – U.S. Regulations

The Hostaform® POM and Celcon® POM product portfolio includes food-contact grades formulated with base resin compliant for use in food-contact applications according to (CFR), Title 21, 177.2470. These grades include a full range of colors including color masterbatches. Any additives present in these grades comply with appropriate, specific FDA regulations.

## 4.8.1 Food/Drinking water contact

### Suitability for applications used in drinking water – Europe

Drinking water applications are regulated on a national level. Celanese has developed a range of products suitable for drinking water applications. For these grades Celanese has received the necessary certificates from certified laboratories. On request, Celanese experts will be instrumental for customers who seek drinking water approval for their applications (parts) with the national notified bodies (test laboratories).

### Suitability for applications used in drinking water – U.S.

Several Hostaform® POM and Celcon® POM grades are certified by NSF International to the NSF/ANSI 61 drinking water standard as materials for use in drinking water systems. A complete listing of the certified products is available on the NSF website.

## 4.8.2 Pharmaceutical / Medical Applications

In order to meet the particularly high standards of materials used in medical applications and to comply with legal requirements that vary by country, Celanese offers specially tailored engineering polymers for healthcare applications.

Hostaform® POM MT® grades are equipped with special characteristics to meet the specific requirements of medical applications. The existing benefits of polyacetal such as high toughness, hardness and stiffness, excellent friction and wear properties and low water absorption, are supplemented by distinguishing features of material quality, conformance, and availability. Extensive testing of each individual lot demonstrates material purity and property consistency. At the same time, a new standard of quality assurance is established.

The following grades are available:

Grade	Description
MT <sup>®</sup> 2U01	low flow, improved toughness for injection molding and extrusion
MT <sup>®</sup> 8U01	unreinforced standard grade
MT <sup>®</sup> 12U01	unreinforced standard grade, medium flowability
MT <sup>®</sup> 12U03	unreinforced standard grade, improved strength
MT <sup>®</sup> 24U01	unreinforced standard grade, best flow properties
MT <sup>®</sup> 8R02	modified friction properties, low noise
MT <sup>®</sup> 12R01	modified friction properties
MT <sup>®</sup> 8F01	PTFE modified
MT <sup>®</sup> 24F01	PTFE, improved flowability
MT <sup>®</sup> 8F02	highly PTFE modified for low speed sliding
MT <sup>®</sup> 8U05	UV detectable general purpose injection molding grade
MT <sup>®</sup> SlideX 1203	standard flow, with tribological modification
MT <sup>®</sup> SlideX 2404	easy flow, with tribological modification

- ▶ USP <88> Class VI
- ▶ ISO 10993-5 Cytotoxicity
- ▶ ISO 10993-6 Implantation
- ▶ ISO 10993-10 Intracutaneous Reactivity
- ▶ ISO 10993-11 System Injection

These Hostaform<sup>®</sup> POM grades in natural color were tested for biocompatibility and met the following requirements:

- ▶ USP <661> Physicochemical
- ▶ ISO 10993-10 Sensitization
- ▶ ISO 10993-11 Pyrogenicity

Select grades were tested and met the following requirements:

For approvals in the U.S., the above-mentioned product grades are listed in Drug Master File No. 11559 and Device Master File No. 1079.

Successful USP testing does not imply our products are suitable for use in all medical and pharmaceutical end-uses. Celanese disclaims any liability for the use of Celanese products in medical applications. In particular, Hostaform<sup>®</sup> POM and Celcon POM<sup>®</sup> are not intended for medical- or dental-implant applications.

The responsibility for evaluating the finished article for safety and conformance to applicable requirements lies with the manufacturer of such article.

Please contact your account manager should you have questions or require additional information on Celanese MT<sup>®</sup> grades.

Hostaform® POM may be run on all standard processing machinery for thermoplastics such as injection molding machines, extruders, injection and extrusion blow-molding machines and compression-molding machines. With the exception of the XAP® grades, pretreatment is not generally necessary, but where the product has been exposed to a damp atmosphere or in contact with water through poor storage arrangements, it must be dried at 100 to 120 °C in a circulating air oven for about 3-6 hours.

### 5.1 Safety recommendations

General safety precautions during processing  
In processing Hostaform® POM, extraction hoods should be installed immediately above the machinery. The melt temperature should not exceed 240 °C, depending on the permissible residence time in the cylinder, and XAP grades should be processed in a smaller temperature window **Fig. 42** (recommended processing temperatures are given in section 3.2). When subjected to excessive thermal stress or residence time in the cylinder, Hostaform® POM is decomposed with liberation of formaldehyde. This gas has a pungent odor and irritates the mucous membranes.

In addition, the pressure of the gaseous decomposition products if the nozzle is obstructed or frozen may be so great that relief through the feed opening of the machine is sought. Should this not be possible, there is a risk that the rising pressure could cause damage to the machine and injury to operators. It is therefore important to ensure that injection nozzles or extruder orifices are never, for example, blocked by plugs of frozen material.

Should thermal degradation in the cylinder be suspected or determined, the material should be run out with the heating switched off. It is advisable to immerse severely degraded material in water to prevent unnecessary odor nuisance.

Hostaform® POM is immiscible with most other thermoplastics; if these should contaminate the

material they will lead, even in small quantities, to inhomogeneous moldings. Special care should be taken with thermoplastics which have a decomposing effect, particularly PVC, since this polymer can induce a severe decomposition reaction. Even in low concentrations, PVC-contaminated Hostaform® POM should on no account be processed.

Hostaform® POM, like many other organic materials, is combustible. It is in the interest of the manufacturer when storing, processing or fabricating plastics to take the necessary fire precautions. Special fire prevention requirements may apply to certain end products and fields of application.

Statutory safety regulations vary from one country to another, and the local and/or national requirements should always be met. It is the responsibility of the raw material processor to ascertain and observe these requirements. Important notes are contained in the safety data sheets, which we will be pleased to supply on request.

In Germany at the present time, a maximum permissible formaldehyde concentration at the workplace (MAK value) of 0.5 ppm is stipulated.

The MAK value is the average of a number of measurements spread over a working day or a shift. These can be carried out with a Dräger gas detector\*) and the appropriate "Formaldehyde 0.2/a" measuring tube. The samples should be taken close to the operator at head height. More details are given in the MAK value lists, which are revised every year and can be obtained from the German employers' liability insurance associations (Berufsgenossenschaften).

### Starting up empty machine

The cylinder temperatures are set to about 200 °C. After the plasticizing cylinder has been filled, a few shots are ejected into the open. Particular attention must be paid to nozzle temperature. If this is too low, the melt will freeze and block the nozzle.

\*) Drägerwerk AG, D-24116 Lübeck, Germany

### Short- and long-term interruption of molding cycles

When the cycle is only briefly interrupted, cylinder temperatures should be reduced slightly but the nozzle temperature may be maintained.

When the molding cycle is interrupted for longer periods, the procedure to be adopted is as follows:

- ▶ stop granule feed
- ▶ switch off cylinder and nozzle heating
- ▶ switch off hot runner heating
- ▶ disconnect cylinder from mold
- ▶ eject melt fully from cylinder.

### Restarting the machine with Hostaform

Heat up the machine and set the cylinder temperature to 150-160 °C. Increase the nozzle temperature to 200 °C and the hot-runner temperature by stages to 190 °C. It is important to ensure that the nozzle as well as the gate point of the hot-runner nozzle are not blocked by a plug of frozen material.

As soon as the correct temperature has been reached and the molding material uniformly heated, a few shots are ejected into the open at a low-screw advance rate.

When the material is flowing freely, it can be injected into the mold as soon as the final processing temperature has been set.

Changing from another thermoplastic to Hostaform® POM thermoplastics requiring higher processing temperatures, such as polyamide or polycarbonate, must be completely removed from the machine by purging with a polyolefin before the machine can be charged with Hostaform® POM. In the same way, plastics unstable at Hostaform® POM processing temperatures and particularly those whose decomposition products promote degradation of Hostaform® POM (for example polyvinyl chloride) must also be completely removed by a polyolefin purge. The detailed procedure to be adopted is as follows:

- ▶ the cylinder heaters are set at the processing temperature for the thermoplastic
- ▶ after it has been thoroughly heated the melt is ejected into the open
- ▶ an easyflowing unmodified polyolefin is forced through in rapid shot sequence until the previous thermoplastic has been completely removed
- ▶ the cylinder and nozzle temperatures are set to 200 °C. With the mold disconnected, residual polyolefin in the cylinder is purged with the aid of Hostaform® POM. Once the Hostaform® POM melt is free of all polyolefin, injection molding may commence.

In cases of doubt, the preferred method is to remove the screw and carry out mechanical cleaning.

### Changing from Hostaform® POM to another thermoplastic

At a melt temperature of about 200 °C, Hostaform® POM is purged from the cylinder into the open with the aid of an easy-flowing polyethylene.

The cylinder temperatures are then set to the appropriate level for processing the required thermoplastic and the operation is continued in the usual way. The directions set out above apply, mutatis mutandis, to extrusion processing.

## 5.2 Injection molding

### 5.2.1 Machine requirements

Hostaform® POM may be processed on all standard injection molding machines in current use, except for vented machines.

Special screws have not generally proved necessary, i.e., it is sufficient to fit the machine with standard screws in accordance with the manufacturer's recommendations. For processing glass-fiber-reinforced Hostaform® POM, it is advisable to use a wear-resistant version of the injection-molding unit such as most machinery manufacturers supply these days as a normal option in their range.

Processing Hostaform® POM on hot-runner molds is state-of-the-art technology. It should be noted, however, that not all systems on the market are equally suitable.

### 5.2.2 Processing conditions

Hostaform® POM is no problem to process. Machine settings for the production of optimum molded

parts – including precision injection moldings – are discussed in the following sections. The settings are detailed in **Fig. 71**. Guidance on startup, shutdown and changeover of material is given in section 5.1.

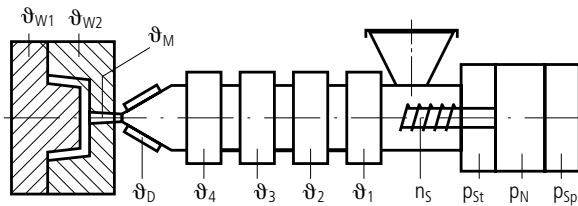
Further information is in the booklet "Processing Guide Hostaform® POM."

### Cylinder temperatures/melt Hostaform® POM

The melt temperature range is between 190 and 230 °C. Optimum processing temperatures are between 190 and 210 °C. With the impact-modified grades, an effective melt temperature of 210 °C should not be exceeded. The optimum melt temperatures for XAP low-emission grades are between 190 and 200°C.

These temperatures can be measured manually in the space in front of the screw tip by inserting a probe. Deviations from the set-point value should normally be corrected by adjusting the cylinder and nozzle heating. Melt temperature should always be monitored in this way because the melt temperature sensors in the injection molding machine do not usually show the actual temperature of the melt.

Fig. 71



max. residence time in the cylinder = 20 min at  $\Theta_M = 210\text{ °C}$

$v_s$  [peripheral velocity of screw] = 0.1 to 0.3 m/s

injection time [s]  $\approx 0.5$  to  $1 \cdot$  wall thickness [mm]

holding pressure time [s]  $\approx 2$  to  $3 \cdot$  wall thickness [mm]

residual cooling time [s]  $\approx 2$  to  $3 \cdot$  wall thickness [mm]

nozzle design: open or shut off nozzle, preferably open

$\Theta_{W1}, \Theta_{W2} = 80$  to  $120\text{ °C}$

$\Theta_M = 190$  to  $210\text{ °C}$  (max.  $230\text{ °C}$ )\*

$\Theta_D = 190$  to  $210\text{ °C}$

$\Theta_4 = 190$  to  $210\text{ °C}$

$\Theta_3 = 190$  to  $200\text{ °C}$

$\Theta_2 = 180$  to  $190\text{ °C}$

$\Theta_1 = 170$  to  $180\text{ °C}$

$n_s = v_s / d \cdot \pi$  (screw speed)

$P_{St} = 0$  to  $40$  bar (typical range:  $1$  to  $2$  MPa)

$P_N = 60$  to  $120$  MPa (typical range:  $80$  to  $100$  MPa)

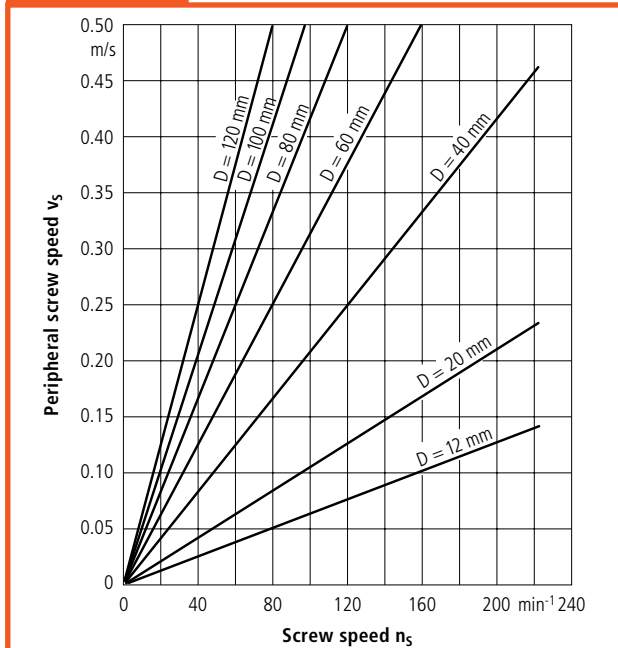
$p_{Sp} = 60$  to  $120$  MPa (typical range:  $80$  to  $100$  MPa)

\*Measure  $\Theta_M$  on material ejected into the open.

The lower melt temperature should be targeted for the S grades (do not exceed  $210\text{ °C}$ ) and should if possible also be used for the easy-flowing grades (potential reduction in cycle time). Vented machines are not recommended.

Typical injection molding conditions for Hostaform

**Fig. 72**



Peripheral screw speed  $v_s$  as a function of screw speed  $n_s$  and screw diameter  $D$

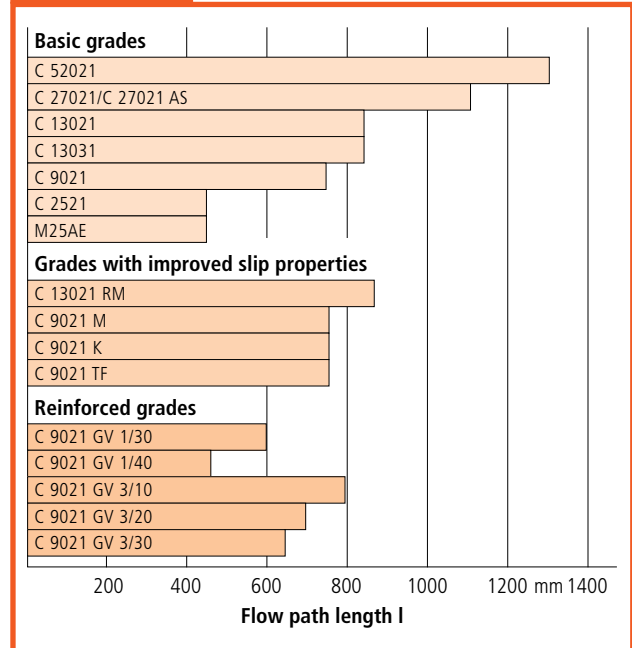
The required melt temperature is achieved through cylinder heating (external heat supply) and friction (heat generated by internal and external friction resulting from rotation of the screw and back pressure). Hot-runner heating has only the function of keeping the melt temperature coming from the cylinder.

The proportion of shear and frictional heat in the total heat supply should be kept as low as possible with Hostaform® POM and hence careful control of screw speed and temperatures is essential (see below). Fig. 72 shows the peripheral screw speed as a function of screw for various screw diameters. With standard screws, peripheral speeds of 0.1 to 0.3 [0.5] m/s should not be exceeded. Suggested temperature settings are given in Fig. 71.

### Mold wall temperatures

The mold wall temperature can be chosen within the 80 to 120 °C range. For engineering components, the optimum mold wall temperature is about

**Fig. 73**



Flow path length  $l$  (spiral flow test) of most Hostaform grades, spiral section thickness 3 mm, injection pressure 100 MPa, melt temperature 205 °C, mold wall temperature 80 °C

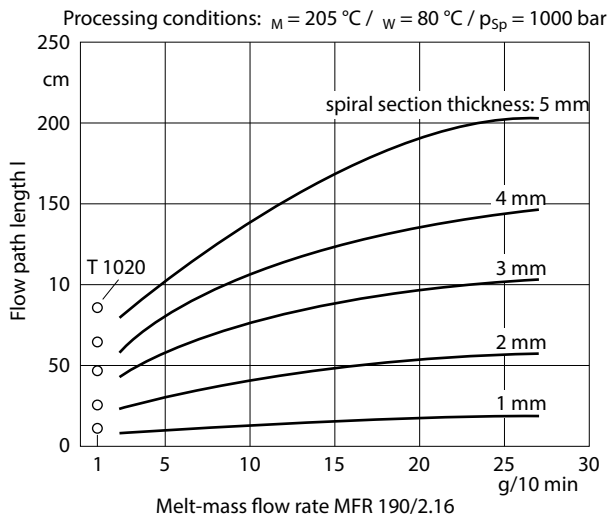
90 °C and for precision components 120 °C. For processing the impact-modified grades, a mold wall temperature of  $q_w \approx 80$  °C is recommended.

### Injection pressure/holding pressure

Injection and holding pressures are necessary to force the melt into the mold cavity and to compensate at least partially for the volume contraction which takes place when the melt freezes. The required injection pressure is dependent on melt viscosity, the flow path/wall thickness ratio and the type of gate. It is normally 60 to 120 MPa.

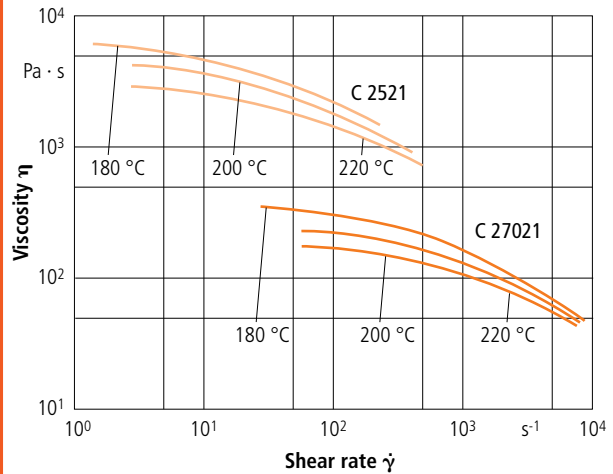
For the manufacture of precision moldings, it has generally proved an advantage for the injection pressure and holding pressure to be equal. This results in minimum variation in the dimensions and weights of the moldings. A melt cushion is required to compensate for volume contraction and maintain the pressure in the mold. The melt cushion amounts to about 1/10 of the shot volume but minimum 4 mm.

Fig. 74



Flowability of the Hostaform C basic grades at various test spiral section thickness

Fig. 75



Viscosity  $\eta$  as a function of shear rate  $\dot{\gamma}$  for Hostaform C 27021 and C 2521

Just as important as the injection and holding pressure to be used is the time during which the pressure is effective. The holding-pressure time must be such that while the material in the gate cross-section remains plastic, sufficient melt can be forced into the mold cavity to compensate for volume contracting during cooling.

The required holding-pressure time is determined by increasing the time while maintaining a constant overall cycle time. The weights of the molding in each shot sequence are determined. If the weight remains constant despite longer holding-pressure time, the correct holding-pressure time in this case has been achieved, provided the gate cross-section is adequately dimensioned. In most cases, holding-pressure time amounts to more than 40% of total cycle time.

The screw advance rate (injection rate) should be set only high enough for the mold cavity to be filled completely so that no sink marks occur. For thin-walled moldings, rapid injection gives the best results, whereas with increasing wall thickness slower rates are preferred.

For appearance colors, it may be necessary to use a very slow injection rate. With increasing screw advance time (slower injection rate), there is a noticeable increase in the toughness of the molded article. Perfect filling must, however, be ensured.

### 5.2.3 Flow properties and flow path length

To characterize the flow behavior of Hostaform® POM, use is made of the melt mass-flow rate MVR 190/2.16 in accordance with ISO 1133 and the length of a spiral injection molded under defined conditions. The Hostaform® POM range at present covers an MFR spread of 1 to 40 cm<sup>3</sup>/10 min and hence meets the requirements of all current production processes. Since choice of the most suitable Hostaform® POM grade depends on the processing method and, in the case of injection molding, also on the design of the molded part and mold (wall thickness, flow path length), the melt mass-flow rate is an important product characteristic and so forms the basis for grade nomenclature and organization of the product range.

**Fig. 73** shows the flow path length of most of the Hostaform® POM grades with a section thickness of  $s = 3$  mm under the same processing conditions.

**Fig. 74** plots spiral flow length (at a melt temperature of 205 °C, a mold temperature of 80 °C and an average injection pressure of 100 MPa) against the melt at various spiral section thickness.

**Fig. 75** shows viscosity  $\eta$  as a function of shear rate  $\dot{\gamma}$  at different melt temperatures for the easy-flowing grade, Hostaform® POM C 27021 and the extrusion grade Hostaform® POM C 2521. The range indicated approximately covers the conditions prevailing in extrusion and injection molding.

### 5.2.4 Shrinkage

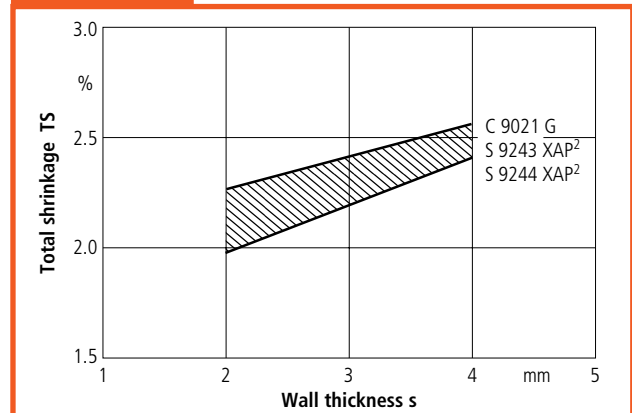
In defining shrinkage, a distinction is made between mold shrinkage MS and after-shrinkage AS. The sum of mold shrinkage MS and after-shrinkage AS is described as total shrinkage TS, Figures 76 to 78.

Note: Shrinkage is measured on test plaques (60 mm x 60 mm x wall thickness) in the flow and transverse directions. The shrinkage result obtained might thus be termed “flat-area” shrinkage. In the case of relatively thick-walled moldings, higher values must be assumed!

Shrinkage is a key factor in the dimensional accuracy of a molding and – particularly when there is differential shrinkage in a molded part – can lead to warpage. It can also have an effect on the nature and level of internal stresses and on the design strength of a molding, especially if shrinkage is restricted.

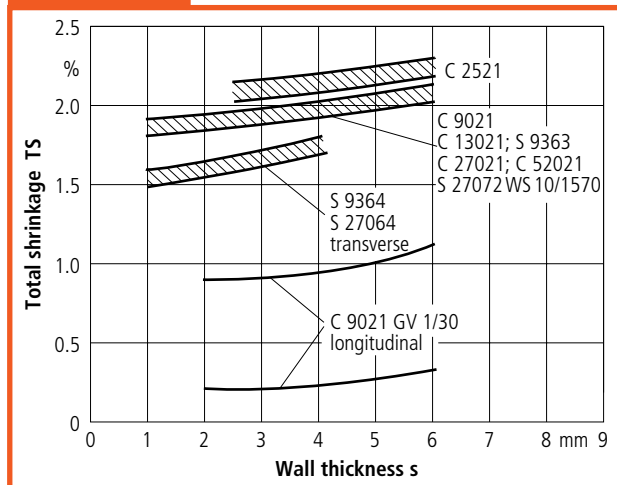
All shrinkage phenomena are dependent not only on the plastic itself but on a variety of factors related to processing, application and design. Hence in a

**Fig. 77**



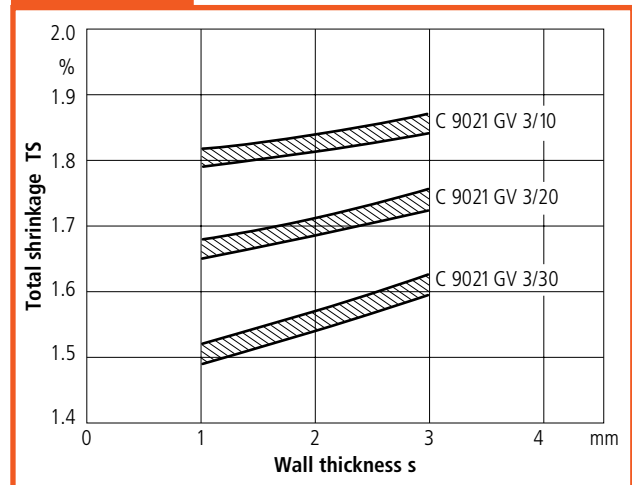
Total shrinkage TS of Hostaform C 9021 G (modified with PE-UHMW), S 9243 and S 9244 as a function of wall thickness ( $\vartheta_w = 90$  °C,  $p_{Sp} = p_N = 1000$  bar,  $\vartheta_M = 205$  °C)

**Fig. 76**



Total shrinkage TS of Hostaform as a function of wall thickness ( $\vartheta_w = 90$  °C,  $p_{Sp} = p_N = 1000$  bar,  $\vartheta_M = 205$  °C)

**Fig. 78**



Total shrinkage TS of glass-phase reinforced Hostaform grades as a function of wall thickness s ( $\vartheta_w = 90$  °C,  $p_{Sp} = p_N = 1000$  bar,  $\vartheta_M = 205$  °C)

brochure describing material properties, it is only possible to quote guide values. The most important variables which influence shrinkage properties are:

**Mold wall temperature:** with increasing mold wall temperature  $q_w$ , mold shrinkage MS increases but after-shrinkage AS decreases **Fig. 79**. This fact, which is of great importance for precision injection molding, means that mold wall temperature must be as high as possible to ensure dimensionally stable moldings (low after-shrinkage). Consequently, greater mold shrinkage has to be accepted.

**Pressure:** during injection molding the molding material is exposed to different pressures such as injection pressure, holding pressure etc. Generally speaking, with increasing pressure, mold shrinkage and total shrinkage decrease **Fig. 80**. This means it is possible during processing to carry out small shrinkage (dimensional) adjustments by changing the injection/holding pressure, which determines mold cavity pressure. But, assuming optimum holding pressure, the mold cavity pressure has practically no effect on the amount of after-shrinkage to be expected.

**Flow path length:** with increasing flow path length, mold cavity pressure drops. Because of this pressure drop, mold shrinkage and total shrinkage in areas remote from the gate are generally greater than in the gate region. However, there is practically no change in after-shrinkage.

**Thickness of the molding:** with increasing molded part thickness, mold shrinkage also increases [14]. This higher mold shrinkage with greater wall thickness can lead to warpage if the molded part exhibits significant wall thickness differences.

**Filler orientation:** while the Hostaform® POM basic grades only exhibit a negligibly small difference between longitudinal and transverse shrinkage, glass-fiber-reinforced Hostaform® POM shrinks much less in the flow direction (because of glass-fiber orientation) than in the transverse direction, **Fig. 76**.

To obtain warp-free moldings, the aim should be to restrict differential shrinkage to a minimum.

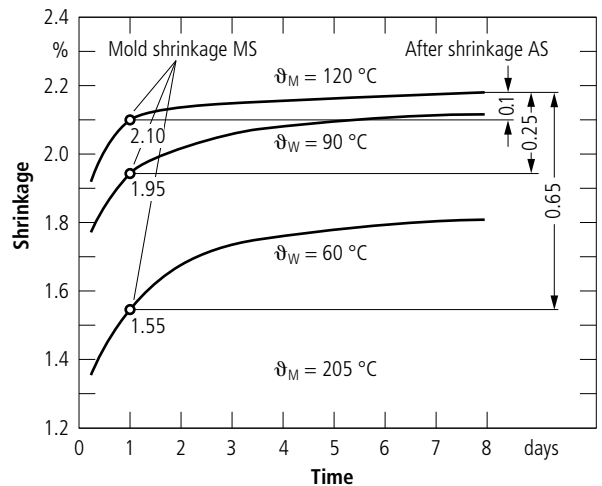
Differential shrinkage is negligible in the case of grades with improved slip properties (e.g., Hostaform® POM C 9021 K), the impact-modified

grades (e.g., Hostaform S 9063) and the glass-sphere-reinforced grades (e.g., Hostaform® POM C 27023 GV 3/30).

The mold shrinkage MS of the grades with improved slip properties closely approximates that of the basic grade Hostaform® POM C 9021. Small differences can be offset by varying the injection/holding pressure.

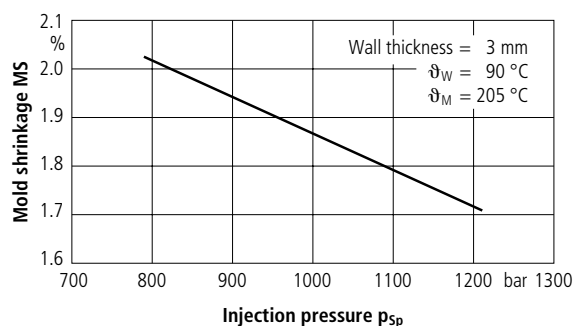
The total shrinkage of the impact-modified grades is shown in **Figures 76 and 77** and that of the glass-sphere-reinforced grades in **Fig. 78**.

**Fig. 79**



**Molds shrinkage MS and after-shrinkage AS of Hostaform C 9021 as a function of time and mold wall temperature**

**Fig. 80**



**Mold shrinkage MS of Hostaform C 9021 as a function of injection pressure**

When planning a step-by-step program for the following activities,

- ▶ molding design

---

- ▶ mold design

---

- ▶ mold construction

---

- ▶ mold proving

Allowance should always be made for changes such as modification to the mold, since shrinkage-induced dimensional or design deviations in a molding are frequently inevitable. Attempts to use mathematical models to predict mold shrinkage as accurately as possible have proved unsuccessful (so far). The same applies to predicting fiber orientation in reinforced thermoplastics. Practical experience with the actual part is thus the most valuable guide.

### 5.2.5 Gate and mold design

The quality of a plastics molding in terms of its suitability for a particular application is basically determined by the following factors:

- ▶ properties of the molding material

---

- ▶ processing of the molding material

---

- ▶ design of the molded part [15]

Only optimization of all three factors will ensure a high-quality molding. This requires close cooperation between the material manufacturer, designer and end user.

Processing involves the machine, mold and temperature control units. For mechanical, thermal and rheological design of a mold, nowadays CAE-based filling calculations are used in critical cases to back up the practical experience which is so necessary. The same applies to the design of complicated moldings.

It is often possible to predict whether a molding will match up to requirements (which should be comprehensively known) with the aid of materials science, but trials which simulate practical conditions as closely as possible should always be carried out to demonstrate serviceability.

Component testing under practical (or simulated) conditions should be accorded the greater importance [14].

Hostaform® POM can be processed without any problem on hot-runner molds [16]; it should be remembered, however, that not all systems are equally suitable. It is advisable to heed the experience of the system suppliers and Celanese.

The type of gate and its location in the mold are determined by various factors such as the following:

- ▶ wall thickness

---

- ▶ flow path

---

- ▶ flow direction

---

- ▶ weld lines

---

- ▶ sink marks

The size of the gate depends on the wall thickness of the molding. If the gate is too large, cooling time and hence cycle time may be unacceptably long.

An undersized gate may cut short the holding-pressure time through freezing effects or cause excessive shear heating of the melt.

As a rough guide, the gate diameter should be about 2/3 of maximum wall thickness. The gate should be located in the area of greatest wall thickness in the molding.

With submarine and pinpoint gates, no finishing is required.

Sprue and diaphragm gates require finishing and generally leave a clearly visible mark on the molding surface.

### 5.2.6 Precision injection molding

Injection molded components with very close dimensional tolerances such as those used in the watch-making and office machinery industries or generally in the field of precision engineering are produced by what is known as the precision injection molding method.

### Optimization of machine settings

Machine settings for the injection molding of precision components are optimized in accordance with the startup procedure shown in Fig. 82. An indispensable aid is a precision balance with an accuracy of 1/100 to 1/1000 g. Generally speaking, the cylinder temperatures and the nozzle temperature ( $q_1, q_2, \dots, q_D$ ) are set on the temperature controllers to provide a steady rise in temperature from the feed zone to the nozzle. A typical temperature profile would be:

- ▶  $\vartheta_1 = 170\text{ °C}$
- ▶  $\vartheta_2 = 190\text{ °C}$
- ▶  $\vartheta_4 = 200\text{ °C}$
- ▶  $\vartheta_D = 210\text{ °C}$

The screw speed ( $n_S$ ) is set as shown in Fig. 72 in accordance with screw diameter and peripheral screw speed  $v_S$ , which could be anything between 0.1 and 0.3 m/s. The specific back pressure ( $p_{S1}$ ) should be between 0 and 20 bar. This serves both to improve melt homogeneity during plasticization and to increase the internal supply of heat due to friction and shear effects. The injection pressure  $p_{Sp}$  should equal holding pressure  $p_N$  and be between 600 and 1200 bar, depending on the trial series. The injection time  $t_S$  is dependent among other things on the wall thickness of the molding. For thin sections it is short and becomes longer as section thickness increases. Cooling time  $t_K$  and changeover time  $t_P$  are set according to empirical values. The mold clamping force  $F$  is dependent on injection pressure, the projected area of the molding(s) and runner system and on the injection rate. It should be sufficient to prevent the mold from being forced open (formation of flash).  $q_{T1}$  and  $q_{T2}$  are the temperatures on the temperature control unit. They should be set so that the mold wall temperature  $q_W$  is  $120\text{ °C}$ . The metering stroke  $s_D$  and melt cushion  $sp$  are determined by the size of the molding.

When all the settings have been made, the machine is started up and after about 30 cycles each molding is weighed. If the weight remains constant within

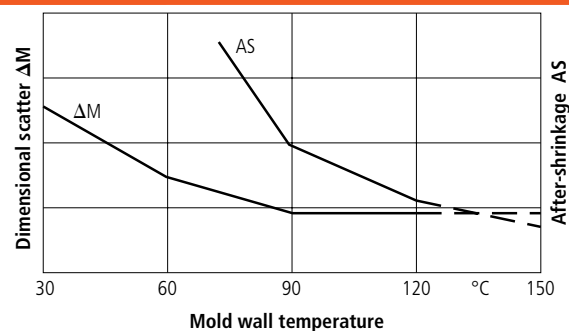
the permitted scatter range for 10 cycles, then it can be assumed that thermal equilibrium has been established in the machine and mold Fig. 83.

The machine cycle is interrupted and the volume of material for one shot is discharged onto a heat-insulating surface. The temperature of the melt is measured with a needle pyrometer and compared with the specified melt temperature for Hostaform® POM ( $205 \pm 5\text{ °C}$ ). If the temperatures are not in agreement, the settings for the cylinder and nozzle heating are adjusted and the procedure for melt temperature measurement repeated. When the actual and specified temperatures agree, the machine is run until weight constancy of the moldings is obtained once more.

The machine cycle is interrupted again to measure the mold temperature. The specified value for both mold wall temperatures ( $q_{W1}, q_{W2}$ ) is  $120\text{ °C}$  because this is the temperature at which dimensional scatter and after-shrinkage are least, Fig. 81. When the specified and actual values agree, the first trial series at a minimum of three different pressure setting levels is commenced. For each pressure setting level, 50-100 trial moldings are produced. These are then evaluated.

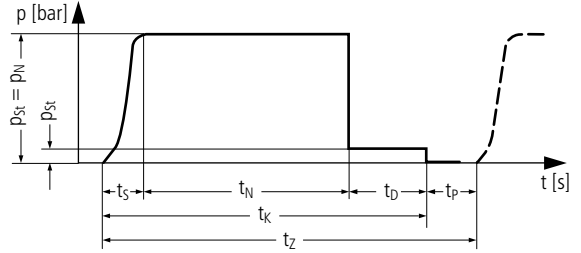
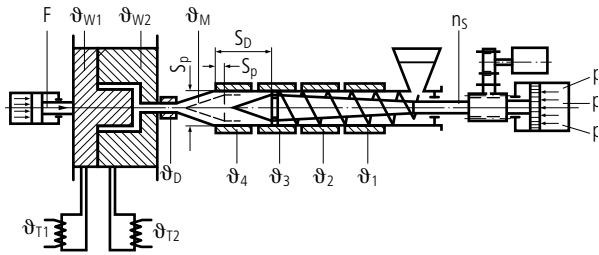
Using statistical methods, the mean value  $X$  and the  $3 \times$  standard deviation ( $\pm 3 s$ ), i.e.,  $6 s$ , for the relevant dimensions (e.g., dimension A and dimension B, Fig. 84) are determined at each injection pressure setting [8].

Fig. 81



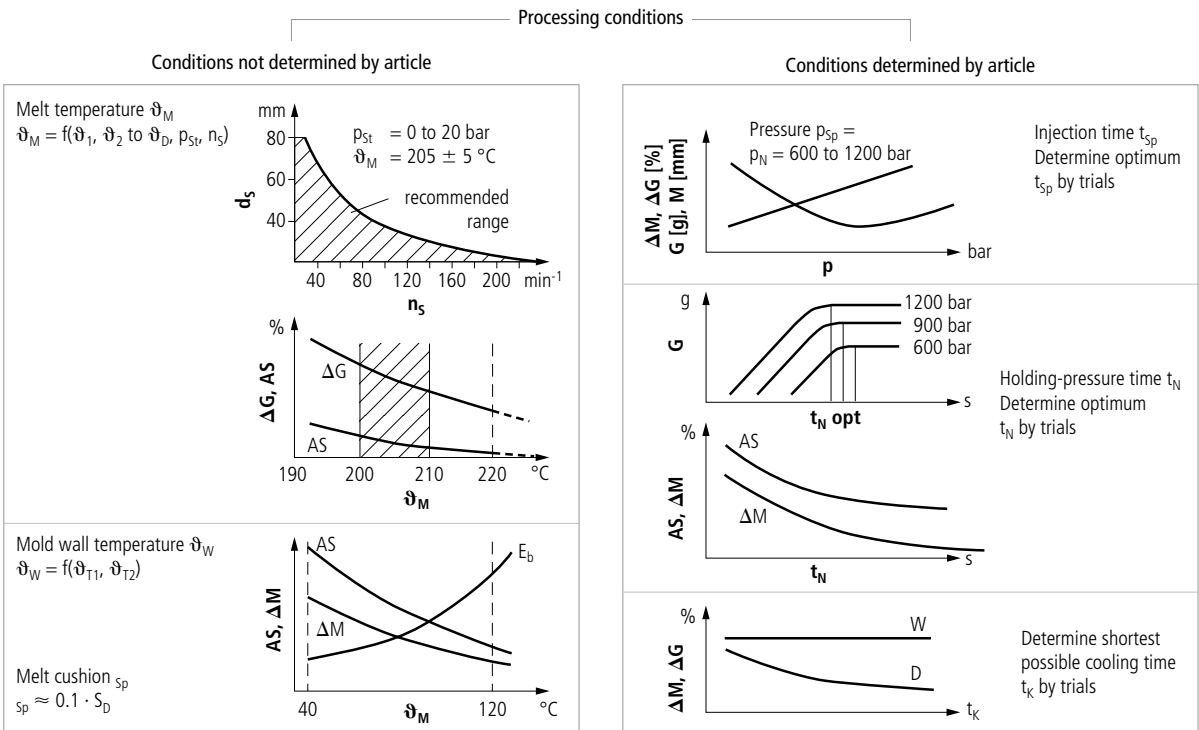
Dimensional scatter DM and after-shrinkage AS of Hostaform as a function of mold wall temperature

Fig. 82



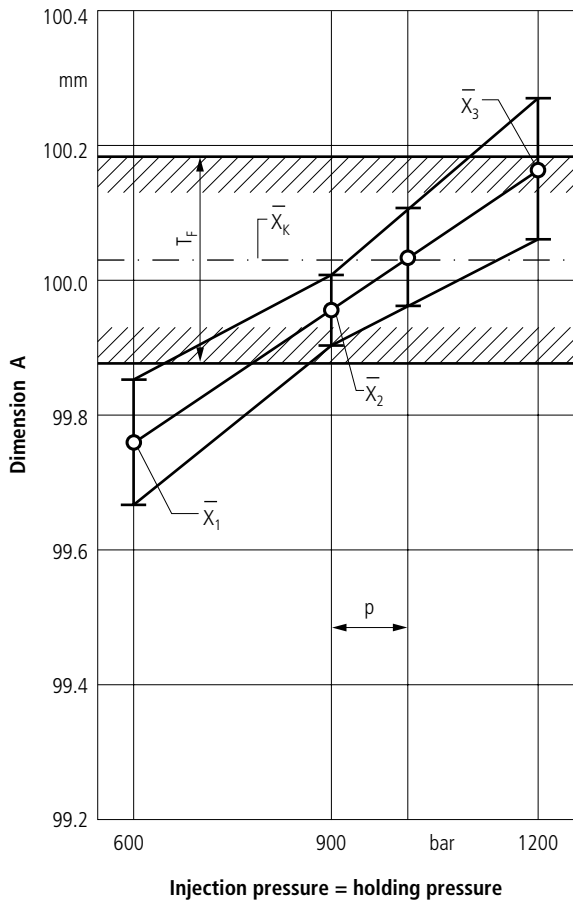
$\vartheta_1, \vartheta_2$ to $\vartheta_D$	°C	cylinder temperatures, nozzle temperature	$n_s$	min <sup>-1</sup>	screw speed	$t_K$	s	cooling time
$\vartheta_M$	°C	melt temperature	F	N	clamping force	$t_D$	s	mold filling time
$\vartheta_{W1}, \vartheta_{W2}$	°C	mold wall temperature	$E_b$	J	fracture energy	$t_p$	s	changeover time
$\vartheta_{T1}, \vartheta_{T2}$	°C	set value on the temperature control units	$S_D$	mm	metering stroke	$t_z$	s	cycle time
$P_{St}$	bar	back pressure	$S_P$	mm	melt cushion	AS	%	after-shrinkage
$P_{SP}$	bar	injection pressure	$d_s$	mm	screw diameter	$\Delta M$	%	dimensional variation
$P_N$	bar	holding pressure	$t_s$	s	injection time	$\Delta G$	%	weight variation
			$t_N$	s	holding-pressure time			

Fig. 82



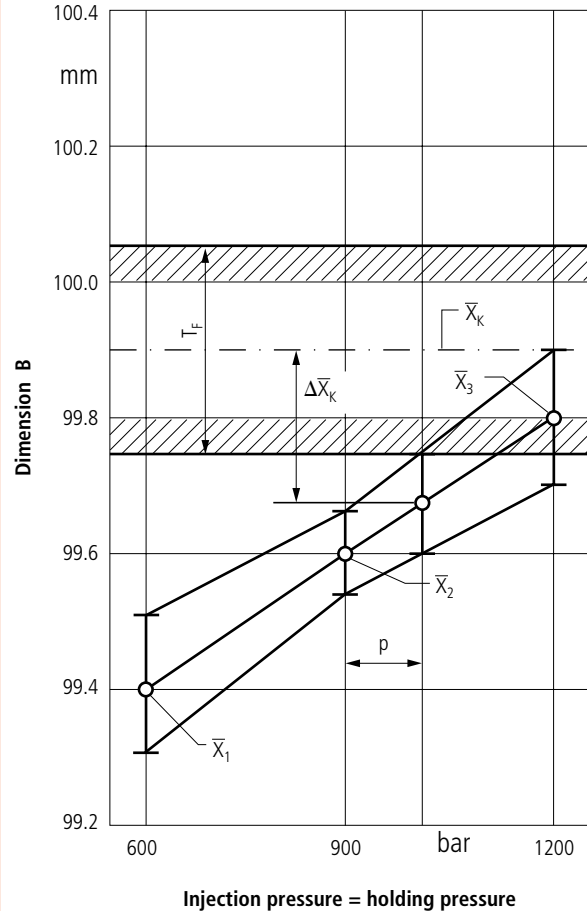
Machine settings for injection molding

Fig. 84



Evaluation of trial moldings

Fig. 84



Evaluation of trial moldings

The target range of tolerance (production tolerance  $T_F$  and check dimension  $X_K$ ) is entered on the diagram and the achieved dimensions and their scatter are compared with the tolerance range and with the position of the optimum pressure. The following procedure is then adopted:

- 1 Carry out pressure correction  $Dp$  to bring as many dimensions as possible within the tolerance range. In so doing, it is important to ensure that the pressure is not adjusted too far from the optimum pressure range as otherwise dimensional scatter will be increased.
- 2 For those dimensions still outside the tolerance range after pressure adjustment, it is necessary to correct the dimensions ( $X_K$ ) of the mold itself (see dimension B in Fig. 84).
- 3 When the modification to the mold is complete, injection molding is resumed at the corrected pressure. The dimensions of the moldings obtained are checked and average weight determined.

From the optimization process, all required processing conditions are known. The correct injection pressure (= holding pressure) is ascertained by evaluating the dimensions of trial moldings and the appropriate weight is determined.

Certain dimensions and weights, as also certain dimensional and weight variations (scatter), can be related to optimum processing conditions. With this knowledge, it is possible to base production control on weight and weight scatter.

Experience has shown that weight scatter should not exceed 0.6% (relative to the average weight of the molding) if dimensional scatter is to be kept below 0.3%.

### Tolerances

The dimensions of the molding are important quality control characteristics. The dimensional scatter in the manufacture of  $\pm 3 s$  (or  $\pm 3 v$ ) must be less than the required production tolerance  $T_F$ .

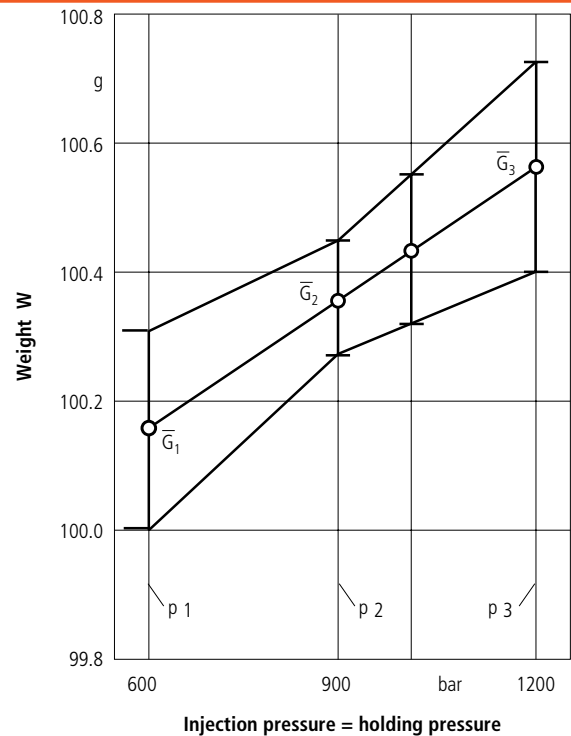
Depending on application requirements, there are three tolerance ranges:

These data are valid for nominal dimensions >10 mm, **Fig. 85**.

A	▶ general-purpose injection molding $T_F < 1.0 \%$ at $\vartheta_W = 60 \text{ }^\circ\text{C}$
B	▶ injection molding of engineering components $T_F < 0.6 \%$ at $\vartheta_W = 90 \text{ }^\circ\text{C}$
C	▶ injection molding of precision components $T_F < 0.3 \%$ at $\vartheta_W = 120 \text{ }^\circ\text{C}$

For nominal dimensions < 10 mm, the linear relationship between tolerance and nominal dimension no longer applies. The percentage tolerance thus increases very rapidly below about 3 mm, **Fig. 86**.

**Fig. 84**

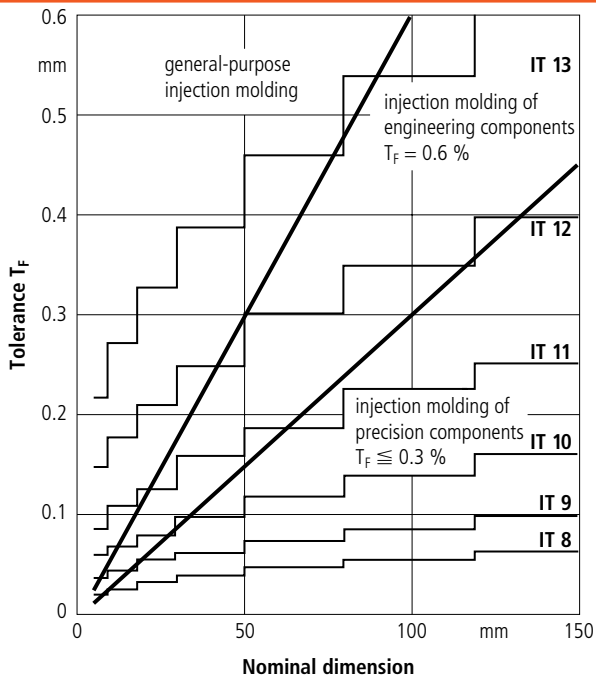


**Evaluation of trial moldings**

- $\bar{X}_K$  = scatter  $6 s$  ( $6v$ ) dimensions and weights
- $\bar{X}_K$  = check dimension 24 h after production
- $\Delta p$  = pressure correction
- $\Delta \bar{X}_K$  = dimensional correction to mold
- $T_F$  = production tolerance

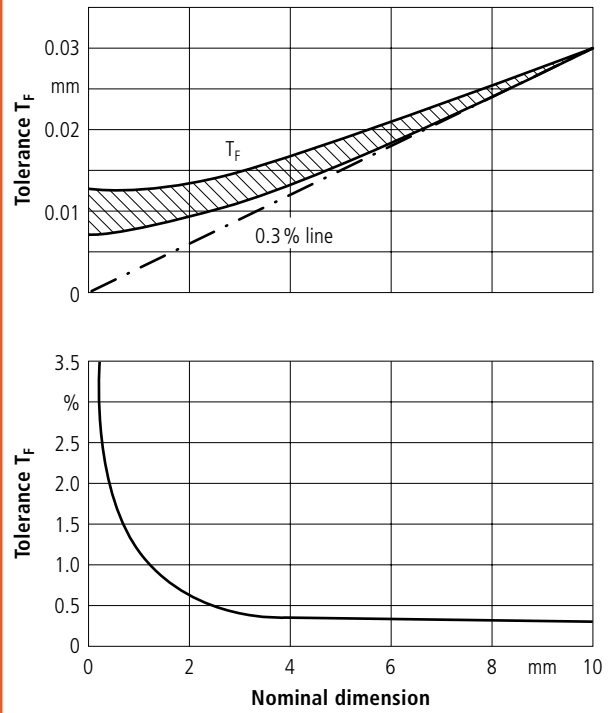
Dimensions A and B:  
different dimensions on the same molding

**Fig. 85**



Tolerance classes for the injection molded dimensions of Hostaform components (IT 8 to IT 13 = ISO basic tolerances)

**Fig. 86**



Production tolerance for Hostaform injection molded precision components with small nominal dimensions



### 5.3 Extrusion

The extrusion method is used mainly to process Hostaform® POM into semi-finished products (round bars, flat bars, hollow profiles and sheets). The dimensions and permissible dimensional and shape variations of such profiles and their supply specifications are standardized in DIN 16 974, 16 975, 16 977 and 16 978.

These semifinished products are frequently machined to make prototypes, pre-production runs or even production parts in small quantities [18].

In extruding Hostaform® POM, the main points to note are the characteristically narrow melting temperature range and the rapidity with which freezing takes place.

#### 5.3.1 Extruder and screw

Hostaform® POM is extruded on conventional single-screw extruders. Twin-screw extruders are not suitable. Cooling or heating of the screw is not required.

Short compression-zone screws have a suitable geometry for extruding Hostaform® POM. Screw lengths of 25 D give the best results. Shorter screws frequently lead to surging.

Processing on vented extruders is not recommended.

#### 5.3.2 Material grades

For extrusion, the basic principle is to select a melt viscosity which will ensure that the plasticized material can be processed with maximum care. In most cases, this means the melt should be as highly viscous as possible, consistent with good homogenization. The Hostaform® POM extrusion grades M30AE and M10AE are ideal materials for this purpose.

#### 5.3.3 Extrusion of round bars

The design and mode of operation of an extrusion plant for round bars are shown in Fig. 84. The difficulty of producing void-free round bars becomes greater with increase in diameter since uniform freezing of the extrudate throughout the cross-section is not possible.

##### Extrusion rate

To remove sufficient heat from the profile despite low thermal conductivity, an effective cooling system and a relatively low production rate are essential. Experience shows that throughput rates of about 7-9 kg/h with single extrusion dies should not be exceeded.

To make full use of the considerably higher production rate of which the extruder is capable, round bars are frequently extruded with multi-orifice dies.

##### Back pressure

The extruded bar is deliberately retarded as it leaves the die by means of brake shoes or by a special haul-off system, so that the freezing melt is placed under such high pressure that no voids are able to form and stresses due to volume contraction are largely avoided. The back pressure should be measured and controlled.

##### Cooling and melt temperature

On leaving the sizing device, the frozen outer skin of the profile must be thick enough to withstand the internal pressure applied. This is achieved by means of external cooling chambers and/or direct water cooling Fig. 87. To shorten the cooling operation, it is advisable to choose a low melt temperature. For this reason, the temperatures normally used are 180-185°C.

### 5.3.4 Extrusion of sheets and flat bars

For sheeting of about 1,000 mm width, extruders with a screw diameter of 90 or 120 mm are used. The polishing rolls are chrome-plated and polished to a mirror finish and are heated with oil or superheated steam. With calendered sheeting, throughputs of about 100 kg/h can be achieved.

To produce sheeting with the minimum internal stress and with a high gloss surface, the two feed rolls should be heated to 130 - 135 °C and the delivery roll to 120-125 °C. Infrared heaters fitted additionally to the roller unit help to ensure uniform cooling, particularly in the edge regions of the sheet, and thus to produce an evenly stress-free profile. As a rule, the sheet edges are trimmed straight once the sheet has passed through the rolls.

Sheeting can also be produced by compression molding. In this case, the material is preplasticized in an extruder, ejected into the heated compression mold, compressed, and then held at constant pressure and cooled to the demolding temperature.

### 5.3.5 Extrusion of pipes and hollow profiles

Up to now, most extruded pipe has been 5-8 mm in outside diameter. It is used as casing for Bowden cables.

Pipes up to an outside diameter of 10-12 mm can be vacuum-sized, whereas larger dimensions can be produced only by a combination of vacuum and internal pressure systems. These points must be borne in mind in designing the die and system of sizing.

A pipe-extrusion line consists of an extruder with die, sizing device, quench bath, haul-off system and cutting and/or reel-up equipment.

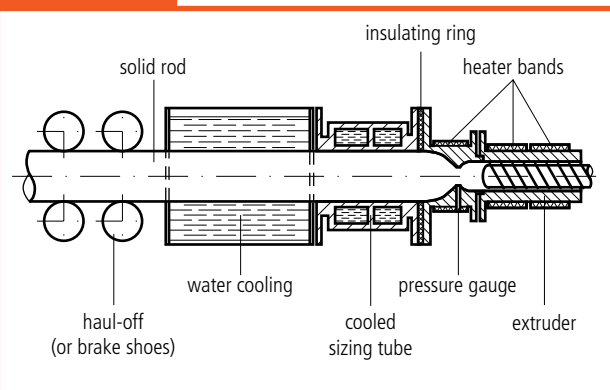
### 5.3.6 Annealing

Despite all countermeasures, a certain amount of uneven cooling will take place over the cross-section and cause internal stresses which have to be relieved by a final heat treatment. This annealing treatment is usually carried out in air or nitrogen (circulating air oven) or in liquids (waxes, oils) at 140 °C for a period of 10 min per mm wall thickness or diameter. To avoid possible formation of stresses as a result of heating up or cooling down, both operations should be carried out slowly and evenly. The times required for these operations are added to the annealing time.

#### Example: round bar 100 mm diameter

Annealing: 100 (mm) x 10 (min/mm)	= 1,000 min	= 16 h 40 min
Heating the loaded oven from cold:		= 3 h 20 min
Cooling the oven to 40-50 °C:		≈ 6 h
Total annealing:		26 h

Fig. 87



Principle of a line for extruding round bars

## 5.4 Extrusion blow molding

### General

Blow molding is a three step process:

1. During step one, a tubular parison is extruded from the die head.
2. During step two, the mold closes, air is introduced to expand the parison into the shape of the mold, and the plastic is cooled while air pressure holds it against the sides of the cold mold.
3. During step three, the air used to blow the part is exhausted, the mold is open, and the part is ejected.

Plastics with high melt-strength are required for blow molding. Celanese has developed several Hostaform® POM materials suitable for blow molding:

Hostaform® POM XT20 and XT90 have good processability along with outstanding low temperature impact.

U10-01 has very high stiffness and outstanding permeation resistance to a wide variety of chemicals.

The shrinkage of Hostaform® POM blow-molded articles is typically between 2 and 4%.

### Machine and mold

Small containers and parts up to one U.S. gallon (5 liters) can be produced using continuous extrusion equipment. Larger parts require accumulator head or reciprocating screw-type blow molders so that the heavy parison can be extruded quickly.

To plasticize the material, a single-stage metering screw with L/D = 16-28:1 and compression ratio = 2.5-4.0 can be used. High shear-mixing sections should be avoided. In order to avoid trapped air on the surface of the part, the cavity should be sandblasted and vented with plenty of slotted core vents. Parting line vents should also be used where possible. Pinch-off geometry should be similar in design to HDPE molds.

POM does not swell as much as other blow molding materials such as HDPE. Therefore, lower die-head-tooling size needs to be increased by a factor of 1.33. (i.e. if HDPE tooling is or would be 60 mm diameter, the lower tooling for POM should be 80 mm).

### Processing

For best melt strength and parison quality, the parison should have a melt temperature between 175-190 °C (do not process below 170 °C or above 210 °C).

To obtain uniform wall thickness from top to bottom, parison programming must be a feature of the molding machine. If parison programming is not available, it will be difficult to avoid thinning at the top of the parison. POM crystallizes rapidly and will tolerate a wide range of mold temperatures (10-100 °C). This can be utilized to fine-tune shrinkage. However, the best balance of surface finish, par and impact are obtained when mold temperatures are between 30-60 °C.

When production ceases, the screw should be run until it is completely empty and, if the machine has an accumulator head, the shot reservoir should be emptied. In addition, the temperatures should be lowered to 125 °C. The machine can then sit this way without purging until it is time to resume production (prior to starting back into production, the temperatures should be raised back to standard set-points and given plenty of time to soak prior to extruding any material). If the machine will sit idle for a significant length of time, purging is recommended. The best purge material is an LDPE with MFR between 0.5 and 2.0 g/10 min. Fractional melt HDPE can also be used as a purge.

POM should not be allowed to come into contact with PVC in the melt phase. This will cause the POM to degrade. When going from POM to PVC or from PVC to POM, the machine should be disassembled and mechanically cleaned.

## 5.5 Injection blow molding

### General

Injection blow molding – like extrusion blow molding – is a two-stage process. The first stage consists in injection molding an inflatable preform in a mold comprising a cavity and core rod. The second stage involves transferring the preform to a blow mold where it is blown into the finished product and cooled, Fig. 88.

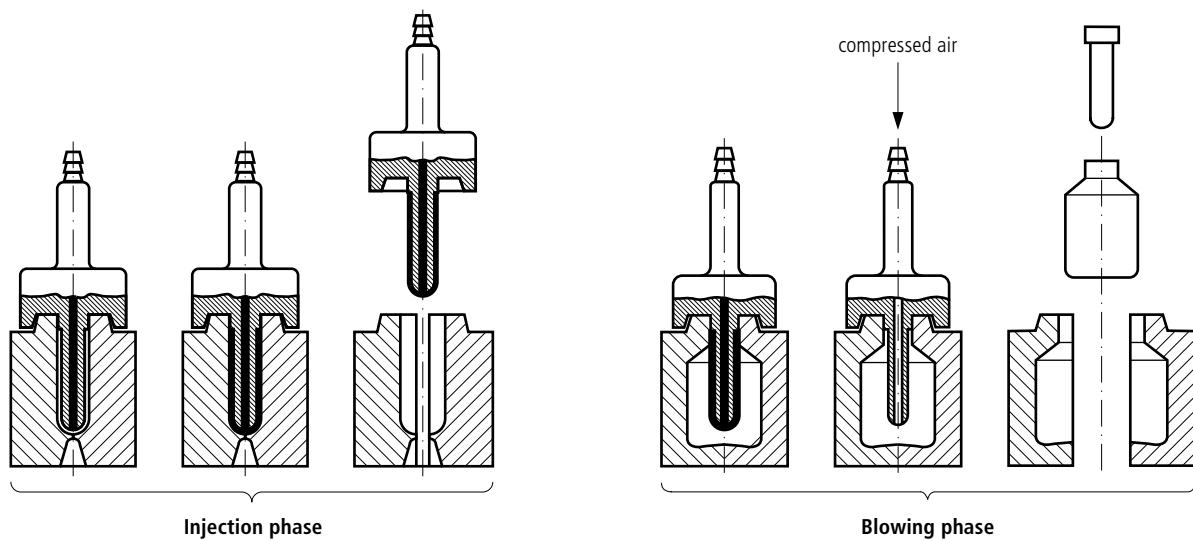
- ▶ high dimensional accuracy
- ▶ uniform wall thickness
- ▶ minimal weight and volume variation
- ▶ no weld lines
- ▶ optimum surface quality
- ▶ improved mechanical properties

An important feature of injection blow molding is that it allows scrap-free production of containers. In addition, the process has a number of other advantages which ensure minimum material requirement and optimum finished-part properties.

However, the advantages have to be weighed against the limitation that containers with an offset opening, additional openings or blow-molded handles cannot be produced by injection molding. This also holds true for bottles with extreme cross-sections or longitudinal sections, for example, flat rectangular cross-sections with a side ratio of  $a:b > 1:2.5$  [9]. Because of its high rigidity and impact strength, Hostaform® POM is suitable for the manufacture of containers subject to internal pressure. The main use of Hostaform® POM in injection blow molding is to produce aerosol containers.

Hostaform® POM C 2521 has proved an ideal grade for injection blow molding.

Fig. 88



Basic principle of injection blow molding

## 5.6 Assembly of moldings and semifinished products

With the present drive toward the efficient, low-cost manufacture of plastics assemblies, the actual technique of assembly has become increasingly important. For manufacturing and fabrication reasons, it is often necessary to produce the component parts separately and then assemble them as required. Hostaform® POM moldings can be joined efficiently to produce assemblies with good resistance to mechanical stress. Various assembly methods are suitable, and these are described in detail in our publication series titled "Design · Calculations · Applications." In series B, "Design of Technical Moldings," our brochures on this subject are the following:

- ▶ Design calculations for snapfit joints in plastic parts
- ▶ Fastening with metal screws
- ▶ Plastic parts with integrally molded threads
- ▶ Design calculations for pressfit joints
- ▶ Integral hinges in engineering plastics
- ▶ Ultrasonic welding and assembly of engineering plastics

Publications in this series are available on request.

### Hot-plate welding

Hot-plate welding has proved to be a successful method of joining Hostaform® POM injection molded components, regardless of pigment or additive content. This method is particularly suitable for joints which are to be mechanically stressed, for large joints, or for components whose particular shape precludes the use of other methods.

The surfaces to be joined are brought up to temperature by light contact with a PTFE-coated hot plate and are then welded together under pressure. The hot-plate temperature should be between 220 and 240 °C. The heating up time is about 5-30 s, depending on the shape of the component and, of course, the melt viscosity of the particular Hostaform® POM component being used. When joining the heated surfaces, it is an advantage to use a welding pressure-control system in which

welding pressure is automatically controlled by the travel path when the mating surfaces reach a predetermined distance apart ( $\approx 0.5$  to 1.5 mm).

### Friction welding

Another low-cost method of joining injection-molded components is friction welding. With this method, it is essential for the joint faces to be rotationally symmetrical.

So far, experience has shown that frictional speeds between 100 and 300 m/min at contact pressures of 0.2 to 0.5 N/mm<sup>2</sup> give successful results. The optimum conditions must be determined for each particular component; these vary with the geometry of the component, the type of joint, the construction of the drive device and the grade of material used.

### Riveting

To join Hostaform® POM components with each other or with parts made from other materials, hot riveting and ultrasonic riveting are suitable methods.

### Hot riveting

In hot riveting, a PTFE-coated tool is brought up to a temperature of about 220 to 230 °C. In the first stage, the rivet is preheated with the tool, and in the following stage, the head is formed with a cold heading tool, **Fig. 89**.

With appropriately designed riveting tools, several rivets can be closed in one operation.

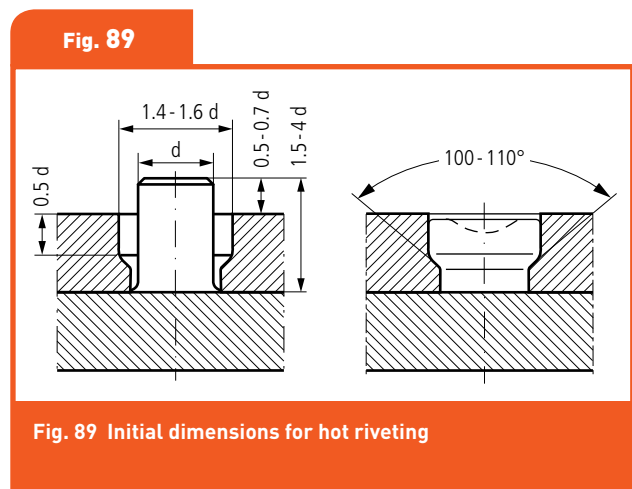


Fig. 90

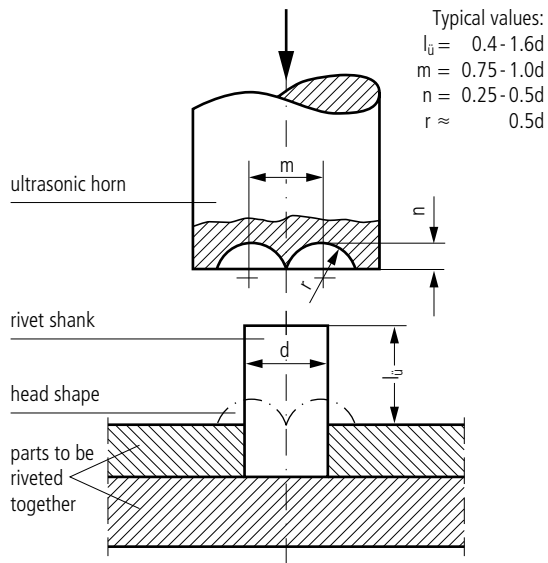


Fig. 90 Initial dimensions for ultrasonic riveting

### Ultrasonic riveting

In ultrasonic riveting, the ultrasonic horn acts additionally as a heating tool **Fig. 90**. Ultrasonically riveted joints are low in stress, have high mechanical load-bearing capacity and are less sensitive to temperature changes. In contrast to cold-riveted joints, they have no noticeable “memory” and thus have good long-term properties. Ultrasonic riveting provides the advantage of short cycle times.

### Adhesive bonding – Conventional adhesive systems

Because of its high solvent resistance, Hostaform® POM is not readily bonded with conventional adhesives. Joints made with pressure-sensitive adhesives are the only type possible. To obtain high-strength bonds, the surfaces must be pretreated. Suitable options include mordant solutions, primer coats or corona discharge.

After thorough surface pretreatment, the following adhesive systems can be used.

Bonds obtained with these adhesive systems have sufficient strength for many applications.

Type of adhesive	Base
Contact adhesives	▶ polychlorobutadiene with isocyanate crosslinking agents
Two-component adhesives	▶ epoxy resin polyurethane nitrile rubber/phenolic resin methacrylate
Hot-melt adhesives	▶ vinyl copolymers
One-component polymerizable adhesive	▶ cyanoacrylate

### 5.7 Surface decoration

Consumer taste and publicity needs are not always fully satisfied by the pigmentation of plastics or by the possibility of obtaining two-color moldings in the injection molding process. There is, in addition, a demand for plastic products which, for decorative and/or information purposes, are given a printed, painted or hot-stamped finish. Flock coating and metallizing of the surface are further special types of finish supplied.

#### 5.7.1 General surface requirements

To attain an aesthetically pleasing decorative effect, it is essential for the moldings to have a smooth, flawless surface. Irregularities or scratches, weld lines or other surface defects are not as a rule obliterated by surface decoration but remain visible on the decorated surface and detract from its appearance. This should be taken into account by exercising care in polishing the mold and by maintaining optimum processing conditions (mold and melt temperature, injection pressure, injection rate).

With nearly all moldings, the surfaces are likely to be soiled and so, generally speaking, a cleaning process should precede surface decoration. Numerous solvents such as paint thinners or trichloroethylene are suitable for this purpose.

A special surface pretreatment is frequently necessary, and may be either chemical or mechanical. Decorative materials applied onto an untreated surface should in any case be given a heat treatment either as they are applied (hot stamping foil) or after application (primers, printing inks).

#### **5.7.1.1 Mechanical pretreatment**

Roughening the molding surface by sandblasting, grinding etc. induces a surface activation and aids adhesion of subsequently applied decorative materials. This method is very costly and therefore is hardly ever used.

#### **5.7.1.2 Acid etching**

The same effect is achieved by controlled slight etching of the surface of the molding in an acid bath. Here again the surface is roughened and takes on a matte appearance. Afterwards the parts must be thoroughly rinsed in warm water at 60 °C. After air drying, the surface can be readily wetted.

#### **5.7.1.3 Primers**

Primers are included among coatings which will adhere to Hostaform® POM moldings without surface pretreatment, but unlike hot-stamping foils or printing inks, primers are used only as aids to decoration, i.e., adhesion promoters for topcoats.

#### **5.7.1.4 Physical pretreatment**

Pretreatments commonly used for other plastics such as flame treatment or exposure to corona discharge are unsuitable for Hostaform® POM because they bring hardly any improvement in adhesion.

#### **5.7.2 Painting**

Conventional topcoat systems are used and the choice of system depends on the paint properties required, e.g., weathering resistance, chemical resistance, scratch resistance, etc.

#### **5.7.3 Vacuum metallizing**

By this process, a mirror-finish, metallized surface can be imparted to Hostaform® POM moldings. The various operations required are as follows:

#### **Pretreatment**

The surfaces to be metallized are first cleaned and degreased, followed by mechanical delustring or preferably acid etching as described in section 5.7.1.2. The primer treatment discussed above also produces satisfactory results.

#### **Base coating**

The quality of adhesion of the evaporated metal depends mainly on the suitability of the basecoat applied to the surface to be metallized. The two-component, polyisocyanate-based lacquers developed specially for vacuum metallizing have proved very good. After application, they are cured in a drying oven.

#### **Vacuum metallizing**

Evaporation of the desired metal onto the article is carried out under the usual conditions for this method.

#### **Topcoating**

The evaporated metal layer is very sensitive to mechanical damage. To protect it from scratches, a colorless or transparent topcoat is applied.

#### **5.7.4 Electropainting**

Hostaform® POM moldings can be coated with a conducting metal layer, then electroplated by the usual electro-chemical method. The surface may be roughened by the etching process described.

It is not possible to obtain firm adhesion of the metal layer to the plastic and for this reason the coating has to be of at least sufficient thickness to be self-supporting.

### 5.7.5 Hot stamping

Hot stamping of Hostaform® POM moldings is a frequently employed method of decoration because pretreatment of the surface is unnecessary. However, the surface must be clean.

The popularity of this method is reflected in the large number of hot stamping foils at present on the market which are suitable for Hostaform® POM. The choice of foil depends on the stamping method to be used (positive stamping, negative stamping, large-area stamping, relief stamping, reciprocating press, rotary press with cylindrical or flat die, stamping with brass or silicone rubber dies), the properties required of the stamping (scratch and abrasion resistance, chemical resistance, weathering resistance) and of course the shade required, including surface finish (glossy, matte). This great variety of choice makes it impossible to give general recommendations on suitable foils and stamping conditions. For example, the required temperature of the stamping die can vary between 100 and 200 °C, depending on the type of foil. Stamping equipment must have accurate control systems for pressure, temperature and die dwell. A uniform contact pressure is particularly important. Exact setting of the stamping die is not in itself sufficient. Care must also be taken to ensure that the molding is firmly and evenly supported. Soft supports such as rubber are unsuitable. High contact pressure, short dwell times and high temperature are the preferred processing conditions. Flat surfaces are of course easier to stamp than domed surfaces, solid parts easier than hollow. In certain cases, preliminary trials may be required.

It is always advisable to consult the foil manufacturer.

Lists of suppliers of the primers, printing inks and stamping foils mentioned above are available on request.

### 5.7.6 Laser marking

Laser marking on plastics is a relatively new technology that is expanding in use. Laser marking replaces more conventional marking technologies

such as adhesive labels, pad printing, ink-jet printing, sublimation printing or hot stamping. Laser marking offers the advantages of producing indelible marks with no surface contact or pre- or post-treatments. Since the mark penetrates the surface of the polymer, the indelible mark helps prevent counterfeiting as any tampering of the mark is obvious compared to printed marks or labels. Laser mark information is controlled by computer software so generating and marking bar codes, data matrix codes, or QR codes is easy.

The word laser is an acronym that stands for Light Amplification by Stimulated Emission of Radiation. The device itself emits a concentrated, precisely focused parallel beam of light. Lasers typically generate this light using an energy source, a lasing medium that allows the light to concentrate, and reflecting mirrors to direct the energy within the lasing medium. There are three types of lasers currently used to laser mark on plastics. They differ primarily in the wavelength of the resulting light energy. This is determined by the lasing medium used in the construction of the laser as described below.

#### TEA-CO<sub>2</sub> Laser

As the name implies, this laser uses carbon dioxide as the lasing medium. The CO<sub>2</sub> laser operates at a relatively long wavelength of 10,600 nm. With Hostaform® POM resins, the major portion of the CO<sub>2</sub> laser energy is absorbed by the polymer matrix. This causes engraving of the surface without significant contrast. CO<sub>2</sub> lasers are not recommended for lasermarking Hostaform® POM grades.

#### Nd:YAG Laser

In contrast to the carbon dioxide laser, the Nd:YAG laser uses a solid state medium of Neodymium Doped Yttrium Aluminum Garnet. The YAG laser, for short, can be constructed to operate either at 1064 nm (near infrared), double frequency at 532 nm (green light), or triple frequency at 355 nm. Fundamental frequency YAG lasers at 1064 nm are the most common systems for marking plastics.

YAG lasers are typically interfaced with a computer to generate the graphics using a vector process achieved with focusing mirrors **Fig. 91**. The YAG laser in a sense writes on the surface of the plastic part. Being interfaced with a computer makes design changes simple without cost of dies or masks, and allows easy indexing for data codes. When operated at the 1064 nm wavelength, the YAG laser creates a mark by melting and foaming the polymer surface to a depth of about 50 microns. When excellent contrast is obtained (bright white mark on a black substrate), the foaming occurs to about 40 microns. By adjusting frequency and power, the amount of foaming can be altered and the color of the resulting mark can be made darker.

Frequency doubled Nd:YAG lasers operate with a wavelength in the visible region at 532 nm (green light) and typically affect pigments and other additives that absorb at that wavelength. The resulting color change is due to a photochemical process occurring to these pigments and additives

in combination with the melting and foaming of the polymer if high peak laser output is used.

Frequency tripled Nd:YAG lasers operate with a wavelength in the UV region at 355 nm. These lasers operate similar to the Excimer Lasers described below

### Excimer Laser

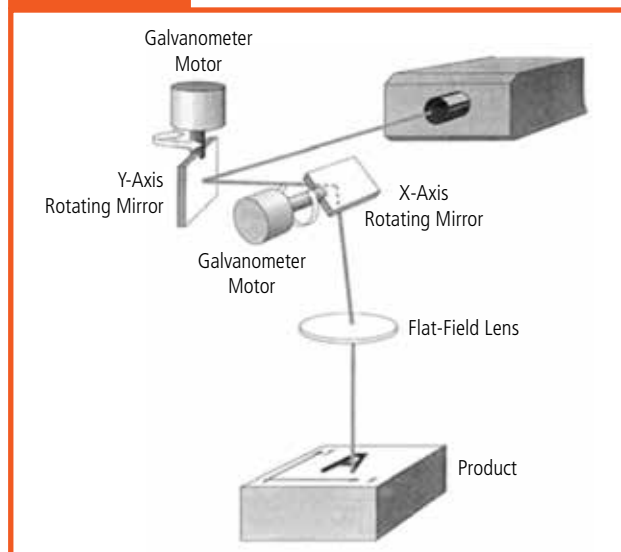
The Excimer laser generates UV light in the wavelength range of 193 nm to 351 nm. Here the laser marks completely by a photochemical process and the polymer matrix is not thermally loaded. Excimer lasers typically act on titanium dioxide or other mineral fillers to generate a dark mark on a white or light-colored substrate. Relatively high levels of pigment or filler are necessary to achieve acceptable contrast. Since the process is photochemical, little to no etching occurs on the polymer surface. Marks penetrate to depths typically less than 40 microns.

#### 5.7.6.1 Lasermarkable Hostaform Grades

Hostaform® POM LM grades have been specially formulated to respond to the energy of the YAG laser which will produce marks with maximum contrast. The three main laser operating variables that affect the laser mark quality are power, pulse frequency and writing speed. In general, high power (70% or higher), relatively low pulse frequency (10KHz) and moderate writing speed (750 mm/sec) are preferred parameters to mark Hostaform® POM LM grades. Changes in the writing density or the writing speed will require appropriate changes in other parameters to achieve the desired contrast.

Black-colored Hostaform® POM C 9021 10/9005 has been optimized to yield high-contrast white marks using a broad range of laser operating parameters when using the YAG laser operated at 1064 nm. The grade also responds well to YAG lasers operating at 532 nm. In addition, Hostaform® POM LM90 natural has been formulated to yield dark marks using the same YAG laser operating at 1064 nm. Other colors, either darker to mark light or light colors to mark dark, are available upon request. It is important

**Fig. 91**



Diagrams showing basic principles of laser marking processes for plastic

to note that with mid-shade colors (medium gray, medium blue, etc.), it is difficult to achieve maximum contrast, as the difference between the base color and the marked color (either lighter mark or darker mark) is not great. Furthermore, special Hostaform® POM LM black grades have been formulated to achieve a blue mark, or a green mark, or a yellow mark, or a pink mark on a black substrate. Other combinations of base color and marked color may be possible. Lasermarkable Hostaform® POM grades are not recommended for CO<sub>2</sub> laser marking systems. Engraving will occur with little to no mark contrast. In addition, while some conventional grades of Hostaform® POM that have not been optimized and are not part of the LM series will mark with a particular laser, there is no guarantee that these non-LM grades will provide consistent marks. Only Hostaform® POM LM grades which have been optimized for the laser marking system will provide consistent marks with the broadest possible window of laser-marking parameters.

### 5.7.6.2 Durability of Hostaform Laser Marks

When there is any marking or printing on plastics, image durability is a major concern. Because laser marks on Hostaform® POM LM grades are indelible and go into the plastic surface, durability, as opposed to that of conventional printing, is excellent. To test this, pad-printed Hostaform® POM C9021 conventional grade and laser-marked Hostaform® POM LM90Z were tested for durability of mark using the Taber Abrasion test. This test was run according to ASTM D4060 using a CS-10 wheel with a 1,000 g load for 100 cycles. As shown in Fig. 92, the Hostaform® POM LM90Z laser-marked sample maintains the same clarity and intensity of the marked image after testing, whereas the pad-printed sample is completely abraded and removed during testing.

### 5.8 CAMPUS\* plastic database

In conjunction with other material manufacturers, Celanese has helped to set up a standardized plastics database which is available on [www.campusplastics.com](http://www.campusplastics.com).

- ▶ have been measured in standard tests on test specimens prepared by standard methods
- ▶ have been carefully chosen to describe the property profiles of plastics with sufficient accuracy to form the basis for material selection.

### 5.9 Shelf-life of Hostaform

The shelf-life of Hostaform® POM materials is unlimited in time provided the material is stored in the original packaging.

Open bags after processing should be closed in order to avoid the contamination of the material.

Pellets exposed to UV light may change in color. Therefore, the storage location should be dry and dark.

Fig. 92



\*] Registered trademark of CWFG, Frankfurt am Main, Germany

Hostaform® POM can be recycled in various ways – some of which have limitations.

### Material recycling

Sprues, rejects etc. can be processed as regrind in blends with virgin material. This includes the common practice of feeding sprues directly back into the injection molding machine. It is important to ensure, however, that regrind is dry, clean and dust-free since otherwise processing stability is reduced. The addition of regrind can also impair feed behavior.

The use of regrind is not recommended for high-quality engineering parts.

Hostaform® POM waste can also be remelted and repelletized but attention must be paid in this case to some specific requirements resulting from its chemical structure. Polymer-type purity and cleanliness of the waste material are particularly important in this process. In practice, this places some limitations on the use of recompounding as a recycling option.

When a material has passed through the recycling loop several times, some deterioration in properties may occur due to degradation and, consequently, there are restrictions on the possible uses for recycled material. This applies particularly to material produced wholly or partly from post-consumer waste. Quality assurance conforming to ISO 9001, which can be achieved in the production of virgin material, is not really possible with these POM recyclates.

Multiple processing can lead to material degradation. This is shown by an increase in the volume flow rate MVR which is an index for reduction in molecular weight, **Fig. 93**. An increase in MVR is accompanied by a loss in thermal stability and frequently in toughness as well.

### Feedstock recycling

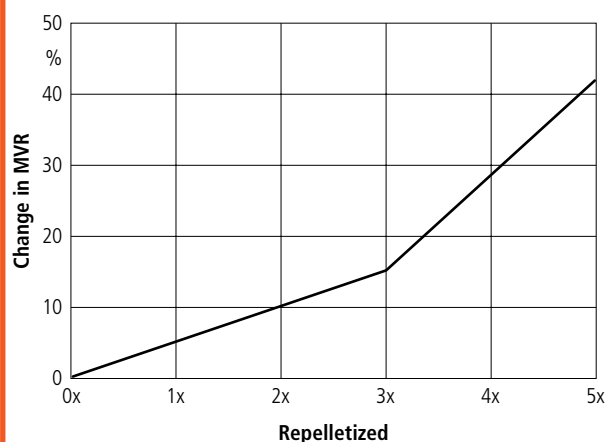
Another recycling option is feedstock recycling, in which waste plastics are broken down into their constituent monomers for reuse as feedstock in new polymerization processes. Virgin material results from this process and so there is no loss in quality, unlike with recyclates. Although Hostaform® POM has a structure which makes it particularly suitable for this option, the process is not at present being exploited industrially owing to an absence of the necessary logistics for collecting the used parts and for economic reasons.

### IMDS

Hostaform® POM products are enclosed in the IMDS (International Material Data System), the material database of the automotive industry. This Internet-based database ([www.mdssystem.com](http://www.mdssystem.com)) gives the automotive industry and their partners information about the used materials in order to afford recycling of end-of-life vehicles.

In addition, our products conform to GADSL (Global Automotive Declarable Substance List), which replaces the corresponding individual standards of the automotive manufacturers. It is available under the following address: <http://www.gadsl.org>.

**Fig. 93**



Change in the volume flow rate (MVR) of polyacetals as a function of multiple processing

- [1] Racké, H.: Welche mechanischen Eigenschaften liefern geeignete Grundlagen für das Konstruieren mit Kunststoffen?  
Kunststoffe, Vol. 55, 1965, pp. 346-350.
- [2] Menges, G.: Abschätzen der Tragfähigkeit mäßig beanspruchter Kunststoff-Formteile.  
Kunststoffe, Vol. 57, 1967, pp. 476-484.
- [3] Gaube, E. and Menges, G.: Knicken und Beulen von thermoplastischen Kunststoffen am Beispiel des Hartpolyäthylens  
Kunststoffe, Vol. 58, 1968, pp. 153-158 and 642-648.
- [4] Wolters, E. and Racké, H.: Wärmealterung, Spannungsrelaxation und Schwingfestigkeit von Acetalcopolymerisat.  
Kunststoffe, Vol. 63, 1973, pp. 608-612.
- [5] Vesely', R. and Kalenda, M.: Das Bewitterungsverhalten von Polyacetal.  
Kunststoffe, Vol. 59, 1969, pp. 107-110.
- [6] Schmidt, H. and Wolters, E.: Verhalten von Acetalcopolymerisaten bei natürlicher Bewitterung und künstlicher Belichtung.  
Kunststoffe, Vol. 61, 1971, pp. 261-265.
- [7] Wolters, E. and Rösinger, S.: Strahlenbeständigkeit von Acetalcopolymerisat.  
Kunststoffe, Vol. 63, 1973, pp. 605-608.
- [8] Herzog, W.: Grundlagen der technischen Statistik und ihre Anwendung bei der Messung von Spritzgußteilen.  
VDI-Bildungswerk, BW 489.
- [9] Voigt, K.-D., Raddatz, E. and Schlüter, R.: Das Spritzblas-Verfahren und spritzgeblasene Kunststoff-Packmittel.  
Verpackungsrundschau, 2, 1973, pp. 112-118; 3, 1973, pp. 192-203.
- [10] Vowinkel, H.: Das Verbinden von Teilen aus Acetalharz und thermoplastischen Polyestern mit Lösungsmitteln.  
Kunststoff-Rundschau, Vol. 20, 1973, pp. 76-78.
- [11] Kloos, F. and Wolters, E.: Morphologie und Eigenschaften schlagzäh modifizierter Acetalcopolymerer.  
Kunststoffe, Vol. 75, 1985, pp. 735-739.
- [12] Schmidt, H. and Meinhard, J.: Morphologie und mechanische Eigenschaften dünnwandiger Spritzgußteile aus Hostaform.  
Plastverarbeiter, Vol. 29, 1978, No. 9.
- [13] Schulz, D. B.: Untersuchungen zum Präzisions-spritzgießen mit Acetal-Copolymerisat auf einer prozeßgesteuerten Spritzgießmaschine.  
Plastverarbeiter, Vol. 29, 1978, No. 11 and Vol. 30, 1979, No. 1.
- [14] Celanese: C.3.3 Design of mouldings made from engineering plastics.
- [15] TCelanese: C.3.4 Guidelines for the design of mouldings in engineering plastics.
- [16] Celanese: C.2.1 Hot runner technology with engineering plastics.
- [17] Celanese: C.3.1 Machining Hostaform®.
- [18] Celanese: C.3.5 Outsert moulding with Hostaform®.
- [19] Celanese: B.1.1 Spur gears with gearwheels made from Hostaform®, Celanex® and GUR®.
- [20] Fleischer, D., Mück, K.-F. and Reuschel, G.: Recycling von Polyacetal.  
Kunststoffe, Vol. 82, 1992, pp. 763-766.
- [21] Witan, K. et. al.: Non-Contact Marking by Laser Beam.  
Kunststoffe German Plastics, 1993, No. 11



## **ENGINEERED MATERIALS**

[celanese.com/engineered-materials](http://celanese.com/engineered-materials)

---

### **Contact Information**

#### Americas

8040 Dixie Highway, Florence, KY 41042 USA

Product Information Service

t: +1-800-833-4882      t: +1-859-372-3244

Customer Service

t: +1-800-526-4960      t: +1-859-372-3214

e: [info-engineeredmaterials-am@celanese.com](mailto:info-engineeredmaterials-am@celanese.com)

#### Europe

Am Unisys-Park 1, 65843 Sulzbach, Germany

Product Information Service

t: +(00)-800-86427-531      t: +49-(0)-69-45009-1011

e: [info-engineeredmaterials-eu@celanese.com](mailto:info-engineeredmaterials-eu@celanese.com)

#### Asia

4560 Jinke Road, Zhang Jiang Hi Tech Park

Shanghai 201203 PRC

Customer Service

t: +86 21 3861 9266      f: +86 21 3861 9599

e: [info-engineeredmaterials-asia@celanese.com](mailto:info-engineeredmaterials-asia@celanese.com)

---

Copyright © 2016 Celanese or its affiliates. All rights reserved.

Celanese®, registered C-ball design and all other trademarks identified herein with the ®, TM, SM, unless otherwise noted, are trademarks of Celanese or its affiliates.

This publication was printed September 2016 based on Celanese's present state of knowledge, and Celanese undertakes no obligation to update it. Because conditions of product use are outside Celanese's control, Celanese makes no warranties, express or implied, and assumes no liability in connection with any use of this information. Nothing herein is intended as a license to operate under or a recommendation to infringe any patents. POM-065-HostaformPOMEU-PM-EN-r1-0916